



## RAPID DETECTION OF GROUPEL IRIDOVIRUS BY LOOP-MEDIATED ISOTHERMAL AMPLIFICATION

Chia-Hsuan Sung

*Animal Health Inspection Division, Bureau of Animal and Plant Health Inspection and Quarantine, Taipei, Taiwan, R.O.C*

Shau-Chi Chi

*Institute of Zoology, National Taiwan University, Taipei, Taiwan, R.O.C*

Kwo-Ching Huang

*Animal Health Inspection Division, Bureau of Animal and Plant Health Inspection and Quarantine, Taipei, Taiwan, R.O.C*

Jenn-Kan Lu

*Department of Aquaculture, National Taiwan Ocean University, Keelung, Taiwan, R.O.C, F0008@mail.ntou.edu.tw*

Follow this and additional works at: <https://jmstt.ntou.edu.tw/journal>



Part of the [Aquaculture and Fisheries Commons](#)

### Recommended Citation

Sung, Chia-Hsuan; Chi, Shau-Chi; Huang, Kwo-Ching; and Lu, Jenn-Kan (2010) "RAPID DETECTION OF GROUPEL IRIDOVIRUS BY LOOP-MEDIATED ISOTHERMAL AMPLIFICATION," *Journal of Marine Science and Technology*. Vol. 18: Iss. 4, Article 12.

DOI: 10.51400/2709-6998.1916

Available at: <https://jmstt.ntou.edu.tw/journal/vol18/iss4/12>

This Research Article is brought to you for free and open access by Journal of Marine Science and Technology. It has been accepted for inclusion in Journal of Marine Science and Technology by an authorized editor of Journal of Marine Science and Technology.

---

## RAPID DETECTION OF GROUPEL IRIDOVIRUS BY LOOP-MEDIATED ISOTHERMAL AMPLIFICATION

### Acknowledgements

This study was supported by the Bureau of Animal and Plant Health Inspection and Quarantine (BAPHIQ), the Council of Agriculture, and Executive Yuan of Taiwan. We would like to express our grateful thanks to Miss Ya-Hui Wu and Miss Chin-Ho Cheng at the Institute of Zoology, National Taiwan University for their help in the grouper iridovirus culture and purification.

# RAPID DETECTION OF GROUPEL IRIDOVIRUS BY LOOP-MEDIATED ISOTHERMAL AMPLIFICATION

Chia-Hsuan Sung\*, Shau-Chi Chi\*\*\*, Kwo-Ching Huang\*, and Jenn-Kan Lu\*\*

Key words: loop-mediated isothermal amplification, LAMP, grouper iridovirus.

## ABSTRACT

Loop-mediated isothermal amplification (LAMP) is a novel nucleic acid diagnostic method that can rapidly amplify a target template under isothermal conditions. Using the LAMP method, a highly specific and sensitive diagnostic system for grouper iridovirus (GIV) detection was designed. Two outer and two inner primers were designed from GIV genome DNA. Reaction time and temperature were optimized for 60 min at 65°C, respectively. The detection limit of LAMP was about 100 ag and 100 times more sensitive than polymerase chain reaction. LAMP was carried out under various heat source reactor without any particular equipment and the reaction products are observed directly, after the addition of ethidium bromide can enhance the inspection of naked-eye. A diagnostic procedure which is rapid, highly sensitive and specific was developed for GIV detection.

## I. INTRODUCTION

Iridoviruses are large icosahedral cytoplasmic deoxyribonucleic acid viruses with viral particle sizes ranging from 120 to 350 nm in diameter. The *Iridoviridae* family can be subdivided into five genera, including *Iridovirus*, *Chloriridovirus*, *Ranavirus*, *Lymphocystivirus* and *Megalocytivirus* [22]. Members of the family are notable for their variability in infecting a range of vertebrate (*Lymphocystivirus*, *Ranavirus*, *Megalocytivirus*) and invertebrate (*Chloriridovirus*, *Iridovirus*) hosts, causing diseases that range in severity from subclinical to lethal [22]. *Ranavirus* and *Megalocytivirus* have infected a wide variety of feral, cultured, and ornamental fish in recent years and cause

serious systemic diseases, and mortality in fish reaches 30 to 100%. Histopathological features in infected fish may include enlargement of cells and necrosis of renal and splenic hematopoietic tissues [16]. Iridovirus infections also have become a major problem in the grouper-culture industry.

Loop-mediated isothermal amplification (LAMP) amplify nucleic acid with high sensitivity, specificity and rapidity under isothermal conditions [13]. The LAMP reaction employs a Bst DNA polymerase and a set of four specific primers that recognize a total of six distinct sequences on the target DNA, and can amplify target nucleic acid fragments to 10<sup>9</sup> copies within 1 h. The most significant advantage of LAMP is the ability to amplify specific sequences under isothermal conditions between 63°C to 65°C, thereby obviating the need for a thermal cycler [13]. Therefore, there is no time loss in thermal changes, and the amplification efficiency of the LAMP method is extremely high [15].

Several reports on LAMP-mediated diagnostic methods have been developed for viral pathogens in aquaculture: white spot syndrome virus (WSSV) [10], yellow head virus (YHV) [12], Taura syndrome virus (TSV) [9], *Macrobrachium rosenbergii* nodavirus (MrNV) [15], extra small virus (XSV) [15], infectious hematopoietic necrosis virus (IHNV) [6], hemorrhagic septicaemia virus (VHS) [19], red seabream iridovirus (RSIV) [1], infectious hypodermal and hematopoietic necrosis virus (IHHNV) [20], koi herpesvirus (KHV) [7] and nervous necrosis virus (NNV) [21].

In this study, we used a LAMP method for the detection of grouper iridovirus, and evaluated its sensitivity, specificity, and convenience. A highly specific set of primers were designed, which are rapid and highly efficient in amplifying the grouper iridovirus target gene.

## II. MATERIALS AND METHODS

### 1. Preparation of Virus and Viral Template DNA

The GF-3 (Grouper Fin-3) cells were cultured with L-15 medium supplement with 10% fetal bovine serum (FBS), and incubated at 28°C. The grouper iridovirus was collected from infected groupers with enlarged spleens from southern Taiwan. The viral DNA was isolated by QIAamp DNA Mini Kit according to the manufacturer's recommendation.

Paper submitted 12/12/08; revised 05/25/09; accepted 08/19/09. Author for correspondence: Jenn-Kan Lu (e-mail: F0008@mail.ntou.edu.tw).

\*Animal Health Inspection Division, Bureau of Animal and Plant Health Inspection and Quarantine, Taipei, Taiwan, R.O.C.

\*\*Department of Aquaculture, National Taiwan Ocean University, Keelung, Taiwan, R.O.C.

\*\*\*Institute of Zoology, National Taiwan University, Taipei, Taiwan, R.O.C.

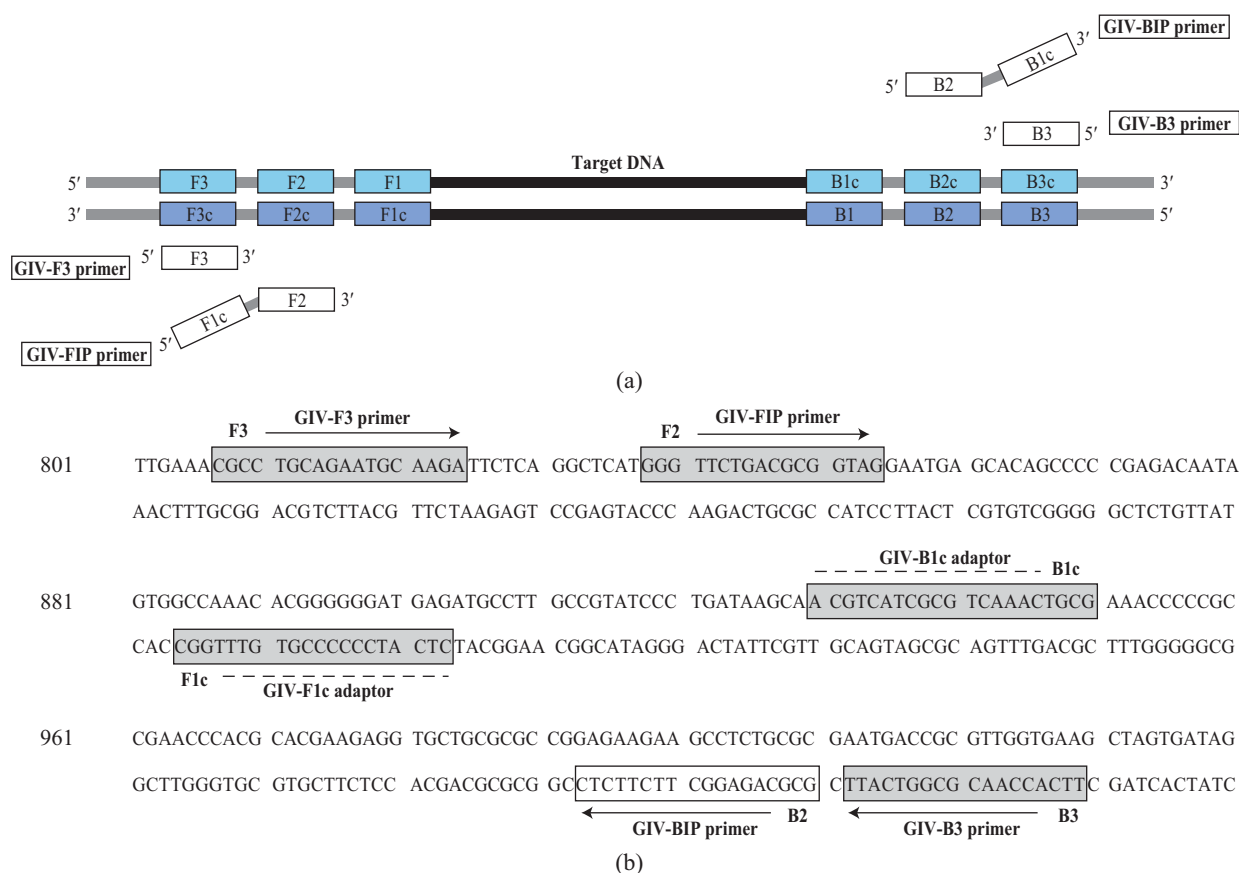

Fig. 1. (a) Schematic diagram of two-inner (FIP and BIP) and two-outer (F3 and B3) primers for LAMP. This diagram was adopted from Eiken Chemical Co. Ltd. (b) Nucleotide sequence of grouper iridovirus genomic DNA (accession no. AY666015) used for the inner and outer primers. The sequences of genomic DNA used for primer design are shown by boxes and arrows.

## 2. Design of Primers for LAMP

Grouper iridovirus-specific LAMP primers were designed according to the NCBI published grouper iridovirus genome sequence (GenBank accession no. **AY666015**) using Primer Explorer software version 4 (<http://primerexplorer.jp/elamp4.0.0/index.html>). A set of four primers composed of two outer and two inner primers was designed. The forward inner primer for grouper iridovirus (GIV-FIP) consisted of the complementary sequence (20 nt) of F1, a TTTT linker and F2 (19 nt): 5'-CTCATCCCCCGTGTGTTGGCTTTTGGGTTCTGACGCGTAG-3'. The backward inner primer for the grouper iridovirus (GIV-BIP) consisted of B1c (22 nt), a TTTT linker and the complementary sequence of B2c (20 nt): 5'-ACGTCATCGCGTCAAACGCTTTTGGCAGAGGCTTCTTCTC-3'. The two outer primers F3 and B3 for the grouper iridovirus (GIV-F3 and -B3) were 5'-CGCCTGCAGAA TGCAAGA-3' and 5'-TTCACCAACGCGGTCATT -3. FIP and BIP structure "the loop" through the reaction, while F3 and B3 facilitate initial strand displacement during DNA synthesis early in the reaction. The location of the primers within the DNA fragment is shown in Fig. 1.

## 3. Determination of LAMP Reaction Conditions

The LAMP was carried out in a total 25  $\mu$ l reaction volume containing 0.8 M each of FIP and BIP, 0.2 M each of the F3 and B3c primers, 1.6 mM dNTPs, 1 M betaine (Sigma), 20 mM Tris-HCl (pH 8.8), 10 mM KCl, 10 mM  $(\text{NH}_4)_2\text{SO}_4$ , 4 mM  $\text{MgSO}_4$ , 0.1% Triton X-100, 8 units of the Bst DNA polymerase large fragment (New England Biolabs), 1  $\mu$ l of target DNA and 5.5  $\mu$ l of distilled water. The mixture was incubated at 65°C for 15, 30, 45, 60, 75 and 90 min, and then the reaction was terminated by heating at 80°C for 2 min. The reaction temperature was optimized (57.5, 60, 62.5, 65 and 67.5°C), and LAMP was carried out at a pre-determined time (60 min). 5  $\mu$ l LAMP products were electrophoresed on 1.6% agarose gels to determine the optimal conditions.

## 4. Sensitivity of the LAMP Assay in Detection of Grouper Iridovirus

The detection limit of the LAMP assay was estimated by testing a 10-fold serial dilution of the grouper iridovirus DNA by the LAMP assay. The reaction was performed at 65°C for 60 min. The result was compared with the detection limit of the commonly used PCR test. All of the LAMP product was analyzed by 1.2% agarose gel electrophoresis and visualized by a UV transilluminator.

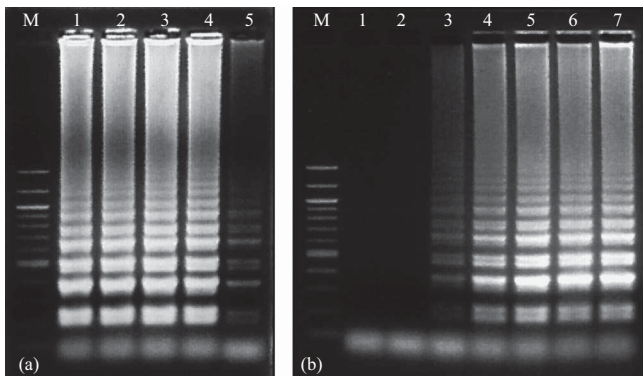

Fig. 2. Results of optimization for LAMP condition. (a) Reaction temperature. Lane 1-5: LAMP carried out at 57.5, 60, 62.5, 65 and 67.5°C, respectively. Lane M: 100 bp DNA ladder. (b) Reaction time. Lane 1-7: LAMP carried out for 0, 15, 30, 45, 60, 75 and 90 min, respectively. Lane M: 100 bp DNA ladder.

### 5. Specificity of the LAMP Assay

The specificity of LAMP primers was examined using total RNA/DNA extracted from NNV-infected grouper, RSIV-infected grouper, and healthy grouper as the template. All of the LAMP product was analyzed by 1.6% agarose gel electrophoresis and visualized by a UV transilluminator.

### 6. Observation and Detection of the LAMP Product

Diluted Ethidium Bromide solution (10 ug/ml), 1:200 concentration in water was used for visual inspection of the LAMP reaction. By observation of the LAMP reaction tube after adding 10 ul diluted EtBr solution, it was noted whether the color turned pink, indicating that the reaction is positive and the LAMP products are present. If the color remains orange, the reaction is negative and the LAMP product is absent. For controlling visual inspection, all of the LAMP product was analyzed by 1.6% agarose gel electrophoresis and visualized by a UV transilluminator. The results of the visual inspection and electrophoresis were compared.

### 7. Convenience of the LAMP Assay

The LAMP was carried out under various heat source reactors including a dry-heating block, a DNA hybridization oven, a circulating water bath and PCR Thermal Cyclers (GeneAmp® PCR System 2700). The reaction was performed at 65°C for 60 min. All of the LAMP product was analyzed by 1.6% agarose gel electrophoresis and visualized by a UV transilluminator.

## III. RESULTS

### 1. Optimization of the LAMP Reaction Conditions

The LAMP was carried out using grouper iridovirus DNA as a template to determine the optimal template and time of reaction. The LAMP product was found at 57.5, 60, 62.5, 65 and 67.5°C (Fig. 2(a)). When the temperature increased to

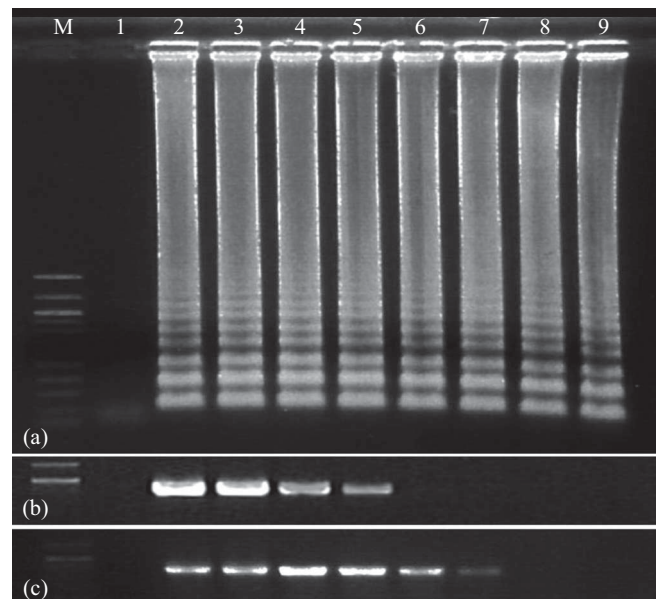

Fig. 3. Sensitivity of GIV-DNA detection by LAMP and nested PCR: (a) LAMP product; (b) PCR product; (c) nested PCR product. Lane 1: negative control, lane 2-9: LAMP carried out using concentrations of GIV-DNA; 1 ng, 100, 10, 1 pg, 100, 10, 1 fg and 100 ag, respectively. Lane 1: negative control, lane M: 100 DNA ladder.

67.5°C, the signal of products decreased significantly. Thus, 65°C was used as an optimal temperature for the following assays. In terms of the reaction time, no amplification of product was found at 15 min, but the LAMP products detected the target DNA early at 30 min (Fig. 2(b)). There was no difference in the LAMP product at 75 and 90 min. Hence, the conditions were optimized to be performed by incubation of the target DNA at 65°C for 60 min.

### 2. Sensitivity of the LAMP Assay in Detection of Grouper Iridovirus

The detection limit of LAMP assay was tested using 10-fold serial dilutions of grouper iridovirus DNA, and compared against results from the PCR test. The LAMP assay detection limit was 100 ag as shown in Fig. 3(a). The first PCR and second PCR detection limits were 1 µg and 100 fg, respectively (Figs. 3(b)-3(c)). The sensitivity of the detection limit by LAMP is 100 times greater than the sensitivity limit of second PCR.

### 3. Specificity of the LAMP Assay

The reaction product of the LAMP assay was detected only when grouper iridovirus DNA was present, giving rise to a typical ladder-like pattern. There were no amplification products detected with RSIV infected grouper DNA, NNV infected grouper RNA and non-infected grouper genomic DNA (Fig. 4). This result indicates that LAMP method is highly specific to grouper iridovirus.

### 4. Observation and Detection of the LAMP Product

As the LAMP reaction progresses, the reaction by-product

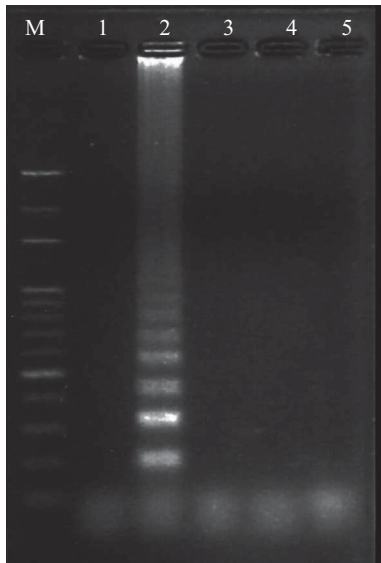

**Fig. 4.** Specificity of the LAMP assay. The assay detected only grouper iridovirus DNA while there no amplification products were detected from other tested organisms or health grouper. Lane M: 100 bp DNA ladder, lane 1: no template negative control, lane 2: DNA from grouper iridovirus, lane 3: DNA from RSIV-infected grouper, lane 4: RNA from NNV-infected grouper and lane 5: DNA from health grouper.

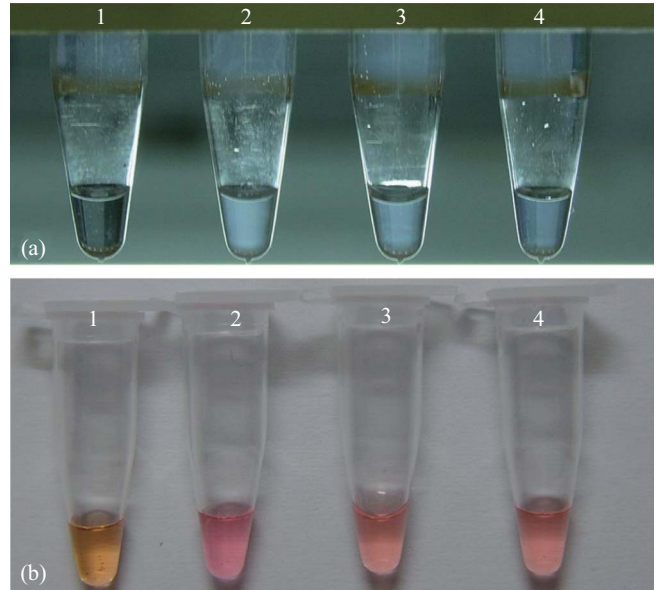

**Fig. 5.** Observation and detection of the LAMP product. Appearance of LAMP product visualized with EtBr stain. 1: no template negative reaction showing orange color, 2: reaction positive for 1 ng grouper iridovirus DNA showing pink coloration; 3: positive LAMP reaction with 1 pg DNA; 4: positive LAMP reaction with 1 fg DNA.

product ions bind to magnesium ions and form a white precipitate of magnesium pyrophosphate. We can identify a positive reaction by the white precipitate produced (Fig. 5(a)). Color changes were noted on visual inspection of LAMP reaction tubes after the addition of EtBr: positive samples turned pink, while negative samples and no template control reactions remained orange (Fig. 5(b)). These observations agreed with the gel electrophoresis results.

### 5. Convenience of the LAMP Assay

The LAMP assay was carried out under various heat source reactors. After 65°C at 60 min, the product was formed by all heat source reactors: in the PCR thermal cycler, dry-heating block, DNA hybridization oven and circulating water bath, the amplification product was no different, as show in Fig. 6.

## IV. DISCUSSION

Grouper iridovirus disease is one of the most important epidemic diseases for the grouper industry in Taiwan. The presence of the virus in orange-spotted grouper (*Epinephelus coioides*), yellow grouper (*Epinephelus awoara*) and king grouper (*Epinephelus lanceolatus*) causes economic loss. At present, the various diagnostic techniques used for the detection of grouper iridovirus include histopathology, viral isolation [5], in situ hybridization [3], electron microscopy [2], ELISA [18], nested PCR [3] and real-time PCR [4]. The PCR approach has been found to be a useful technique for grouper iridovirus diagnosis. However, PCR is still technically demanding and

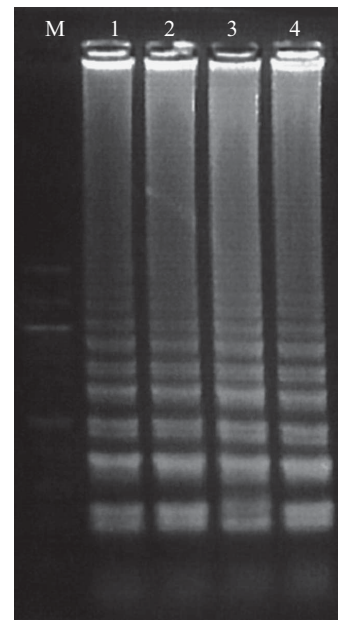

**Fig. 6.** Convenience of the LAMP assay. The LAMP assay was carried out under different heat source reactor. Lane 1: heating block, lane 2: PCR system, lane 3: hybridization oven, and lane 4: water bath, lane M: 100 bp DNA ladder.

requires more than 2-6 h for complete diagnosis. LAMP is a novel method that facilitates rapid nucleic acid amplification using only simple equipment. LAMP is also a sensitive method which can amplify a few DNA copies in less than 1 h



under isothermal condition [13]. The amplification efficiency of the LAMP method is high because there is no time loss for thermal change due to its isothermal reaction [8]. The LAMP reaction has been successfully established in diagnosing viral infection in several species of mammals, plants, fish and shellfish [17].

In this study, the LAMP diagnostic protocol was carried out for the detection of grouper iridovirus. The two sets of primer used, outer and inner, were able to amplify a 223 bp sequence of purine nucleoside phosphorylase gene. The LAMP reaction conditions were optimized by incubation of the target DNA with the specific four primers at 65°C for 60 min. The amplified products appeared as a ladder-like pattern on the gel due to the cauliflower-like structures [14]. Although the LAMP assay could detect grouper iridovirus by incubation at 65°C after 30 min, it was optimized by incubation for 45 or 60 min when there is an extremely low amount of viral DNA. In this study, the LAMP assay detected grouper iridovirus DNA at a dilution of 1 in 10<sup>6</sup>, which was 100 times more sensitive than the limit of nested (or second) PCR. The detection limit of red sea bream iridovirus (RSIV) and turbot reddish body iridovirus (TRBIV) were 10 and 100 times more sensitive than conventional PCR [1, 23]. Mao *et al.* (2008) using LAMP method (containing loop primers) to detect Singapore grouper iridovirus (SGIV), the sensitivity was about 1000 times than the nested PCR system [11].

Several methods may be used to check for the LAMP reaction; the results of naked-eye inspections are shown in Fig. 5. The color of a positive reaction product of LAMP was pink after the addition of EtBr, whereas the original orange color did not change if no reaction products were produced. In addition EtBr, SYBR Green I is another useful nucleic stain. After addition of SYBR Green I, the positive LAMP products turned green, while the negative reaction products remained orange [6, 19, 20]. Thus, using nucleic stain for inspection of LAMP products can quickly recognize the positive samples without gel electrophoresis.

In conclusion, the LAMP protocol is rapid, sensitive, specific and convenient for detection of grouper iridovirus DNA. The test requires only a heat source reactor and is completed in 1 h compared with 3-4 h for nested PCR. Considerably less time is required to obtain a result using EtBr stain, compared with traditional gel electrophoresis.

## ACKNOWLEDGMENTS

This study was supported by the Bureau of Animal and Plant Health Inspection and Quarantine (BAPHIQ), the Council of Agriculture, and Executive Yuan of Taiwan. We would like to express our grateful thanks to Miss Ya-Hui Wu and Miss Chin-Ho Cheng at the Institute of Zoology, National Taiwan University for their help in the grouper iridovirus culture and purification.

## REFERENCES

1. Caipang, C. M., Haraguchi, I., Ohira, T., Hirono, I., and Aoki, T., "Rapid detection of a fish iridovirus using loop-mediated isothermal amplification (LAMP)," *Journal of Virological Methods*, Vol. 121, pp. 155-161 (2004).
2. Chao, C. B., Chen, C. Y., Lai, Y. Y., Lin, C. S., and Huang, H. T., "Histological, ultrastructural, and in situ hybridization study on enlarged cells in grouper *Epinephelus* hybrids infected by grouper iridovirus in Taiwan (TGIV)," *Diseases of Aquatic Organisms*, Vol. 58, pp. 127-142 (2004).
3. Chao, C. B., Yang, S. C., Tsai, H. Y., Chen, C. Y., Lin, C. S., and Huang, H. T., "A nested PCR for the detection of grouper iridovirus in Taiwan (TGIV) in cultures hybrid grouper, giant seaperch and largemouth bass," *Journal of Aquatic Animal Health*, Vol. 14, pp. 104-113 (2002).
4. Chen, L. M., Wang, F., Song, W., and Hew, C. L., "Temporal and differential gene expression of Singapore grouper iridovirus," *Journal of General Virology*, Vol. 87, pp. 2907-2915 (2006).
5. Chou, H. Y., Hsu, C. C., and Peng, T. Y., "Isolation and characterization of a pathogenic iridovirus from cultured grouper (*Epinephelus* sp.) in Taiwan," *Fish Pathology*, Vol. 33, pp. 201-206 (1998).
6. Gunimaladevi, I., Kono, T., Lapatra, S. E., and Sakai, M., "A loop mediated isothermal amplification (LAMP) method for detection of infectious hematopoietic necrosis virus (IHNV) in rainbow trout (*Oncorhynchus mykiss*)," *Archives of Virology*, Vol. 150, pp. 899-909 (2005).
7. Gunimaladevi, I., Kono, T., Venugopal, M. N., and Sakai, M., "Detection of koi herpesvirus in common carp, *Cyprinus carpio* L., by loop-mediated isothermal amplification," *Journal of Fish Diseases*, Vol. 27, pp. 583-589 (2004).
8. Kalinina, O., Lebedeva, I., Brown, J., and Silver, J., "Nanoliter scale PCR with TaqMan detection," *Nucleic Acids Research*, Vol. 25, pp. 1999-2004 (1997).
9. Kiatpathomchai, W., Jareonram, W., Jitrapakdee, S., and Flegel, T. W., "Rapid and sensitive detection of Taura syndrome virus by reverse transcription loop-mediated isothermal amplification," *Journal of Virological Methods*, Vol. 146, pp. 125-128 (2007).
10. Kono, T., Savan, R., Sakai, M., and Itami, T., "Detection of white spot syndrome virus in shrimp by loop-mediated isothermal amplification," *Journal of Virological Methods*, Vol. 115, pp. 59-65 (2004).
11. Mao, X. L., Zhou, S., Xu, D., Gong, J., Cui, H. C., and Qin, Q. W., "Rapid and sensitive detection of Singapore grouper iridovirus by loop-mediated isothermal amplification," *Journal of Applied Microbiology*, Vol. 105, pp. 389-397 (2008).
12. Mekata, T., Kono, T., Savan, R., Sakai, M., Kasornchandra, J., Yoshida, T., and Itami, T., "Detection of yellow head virus in shrimp by loop-mediated isothermal amplification (LAMP)," *Journal of Virological Methods*, Vol. 135, pp. 151-156 (2006).
13. Mori, Y., Nagamine, K., Tomita, N., and Notomi, T., "Detection of loop-mediated isothermal amplification reaction by turbidity derived from magnesium pyrophosphate formation," *Biochemical and Biophysical Research Communications*, Vol. 289, pp. 150-154 (2001).
14. Notomi, T., Okayama, H., Masubuchi, H., Yonekawa, T., Watanabe, K., Amino, N., and Hase, T., "Loop-mediated isothermal amplification of DNA," *Nucleic Acids Research*, Vol. 28, e63 (2000).
15. Pillai, D., Bonami, J. R., and Sri, Widada, J., "Rapid detection of *Macrobrachium rosenbergii* nodavirus (MrNV) and extra small virus (XSV), the pathogenic agents of white tail disease of *Macrobrachium rosenbergii* (De Man), by loop-mediated isothermal amplification," *Journal of Fish Diseases*, Vol. 29, pp. 275-283 (2006).
16. Qin, Q. W., Chang, S. F., Ngoh-Lim, G. H., Gibson-Kueh, S., Shi, C., and Lam, T. J., "Characterization of a novel ranavirus isolated from grouper *Epinephelus tauvina*," *Diseases of Aquatic Organisms*, Vol. 53, pp. 1-9 (2003).
17. Savan, R., Kono, T., Itami, T., and Sakai, M., "Loop-mediated isothermal amplification: An emerging technology for detection of fish and shellfish pathogens," *Journal of Fish Diseases*, Vol. 28, pp. 573-581 (2005).
18. Shi, C., Wei, Q., Gin, K. Y., and Lam, T. J., "Production and characterization of monoclonal antibodies to a grouper iridovirus," *Journal of Virological Methods*, Vol. 107, pp. 147-154 (2003).

19. Soliman, H. and El-Matbouli, M., "Reverse transcription loop-mediated isothermal amplification (RT-LAMP) for rapid detection of viral hemorrhagic septicaemia virus (VHS)," *Veterinary Microbiology*, Vol. 114, pp. 205-213 (2006).
20. Sun, Z. F., Hu, C. Q., Ren, C. H., and Shen, Q., "Sensitive and rapid detection of infectious hypodermal and hematopoietic necrosis virus (IHHNV) in shrimps by loop-mediated isothermal amplification," *Journal of Virological Methods*, Vol. 131, pp. 41-46 (2006).
21. Sung, C. H. and Lu, J. K., "Reverse transcription loop-mediated isothermal amplification for rapid and sensitive detection of nervous necrosis virus in groupers," *Journal of Virological Methods*, Vol. 159, pp. 206-210 (2009).
22. Williams, T., Barbosa-Solomieu, V., and Chinchar, V. G., "A decade of advances in iridovirus research," *Advances in Virus Research*, Vol. 65, pp. 173-248 (2005).
23. Zhang, Q., Shi, C., Huang, J., Jia, K., Chen, X., and Liu, H., "Rapid diagnosis of turbot reddish body iridovirus in turbot using the loop-mediated isothermal amplification method," *Journal of Virological Methods*, Vol. 158, pp. 18-23 (2009).