



## DEVELOPMENT OF AN INTELLIGENT ENERGY SAVING HEAT PUMP FOR WATER HEATER WITH FUZZY LOGIC CONTROLLER

Cong-Hui Huang

Department of Automation and Control Engineering, Far East University, Tainan County, Taiwan, R.O.C.,  
ch\_huang@cc.feu.edu.tw

Follow this and additional works at: <https://jmstt.ntou.edu.tw/journal>



Part of the [Controls and Control Theory Commons](#)

### Recommended Citation

Huang, Cong-Hui (2014) "DEVELOPMENT OF AN INTELLIGENT ENERGY SAVING HEAT PUMP FOR WATER HEATER WITH FUZZY LOGIC CONTROLLER," *Journal of Marine Science and Technology*. Vol. 22: Iss. 6, Article 11.

DOI: 10.6119/JMST-014-0321-11

Available at: <https://jmstt.ntou.edu.tw/journal/vol22/iss6/11>

This Research Article is brought to you for free and open access by Journal of Marine Science and Technology. It has been accepted for inclusion in Journal of Marine Science and Technology by an authorized editor of Journal of Marine Science and Technology.

---

## DEVELOPMENT OF AN INTELLIGENT ENERGY SAVING HEAT PUMP FOR WATER HEATER WITH FUZZY LOGIC CONTROLLER

### Acknowledgements

The author would like to thank the National Science Council of the Republic of China, Taiwan, for financially supporting the research under Contract No. NSC 102-2221-E-269-018.

# DEVELOPMENT OF AN INTELLIGENT ENERGY SAVING HEAT PUMP FOR WATER HEATER WITH FUZZY LOGIC CONTROLLER

Cong-Hui Huang

Key words: fuzzy logic control, energy saving, heat pump, intelligent control.

## ABSTRACT

There is a growing awareness of the importance of using clean and environmentally friendly sources of energy. This paper presents the development of an intelligent energy saving heat pump for a water heater with a fuzzy logic controller that analyzes the heating efficiency of the heat pump heater. The fuzzy logic controller is employed for developing a heating algorithm to raise the efficiency of the heat pump heater and suppress unnecessary heating at high temperatures. Experimental results show that our heat pump heater produces an energy saving of 60% of total energy input, compared to the 23% for a gas heater operating at the same temperature. The system can work throughout the year and provide users with water at a required temperature. In winter, the Coefficient of Performance (COP) of the heat pump heater can reach a range of 2.1-2.5, while in summer it achieves around 2.61-2.95.

## I. INTRODUCTION

The energy requirements of modern human society are constantly increasing. These, combined with the depletion of energy sources and environmental concerns, have compelled humanity to look at means of reducing energy consumption and improving energy conversion efficiency. Water heaters have become an essential domestic appliance in daily life. The most common heaters on the market are gas heaters and electric heaters. Their small volume and low price make them a popular choice for supplying hot water. However, the use of traditional energy sources causes environmental pollution, and gas heaters have safety problems related to carbon monoxide poisoning. In recent years, with environmental concerns in mind, government and industry have been actively promoting

solar water heaters [7]. However, solar water heaters do not work at night and on cloudy days, and cannot be relied upon to provide hot water in all weather conditions [12]. Thus, the heat pump heater technique provides a good alternative [13].

In a heat pump heater system, a change in the outside air temperature affects the overall efficiency. In winter, the outside air temperature is low, and the efficiency of heat conversion is also low, whereas the efficiency is relatively high in summer. The operating cost therefore varies with season. Normal heat pump heaters can only heat water to a specified constant temperature. In such a mechanism, the heat pump system is required to maintain the water at a high temperature, and this leads to unnecessary energy consumption [4, 10]. In view of this, the present study is dedicated to the development of an intelligent heat pump heater that can take into account environmental factors and water-use habits. A heating algorithm derived from a fuzzy control system based on fuzzy logic is used to control the water temperature, thereby achieving improved energy savings and supplying hot water with a stable temperature.

## II. MECHANISMS OF THE HEAT PUMP WATER HEATER

### 1. Mechanism of the Refrigeration Cycle

The vapor-compression cycle is the most widely used refrigeration cycle at present. As shown in Fig. 1, the main components include a compressor, condenser, evaporator, and expansion valve [15, 18].

- i) *Compressor*: The refrigerant enters the compressor at low pressure as a low temperature vapor. It is compressed through externally supplied pressure and exits the compressor at a high pressure and temperature, providing a driving force for the whole refrigeration system.
- ii) *Condenser*: The high pressure and high temperature vapor enters the condenser, which removes the additional heat at a constant pressure. The refrigerant leaves the condenser as a high-pressure and high-temperature liquid.
- iii) *Expansion valve*: After leaving the condenser, the refrigerant passes through the expansion valve or capillary tube,

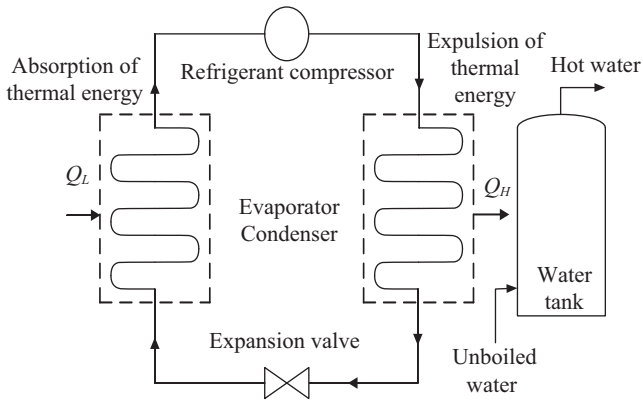

Fig. 1. Diagram of the heat pump heater ( $Q_H = Q_L + W_E > W_E$ ).

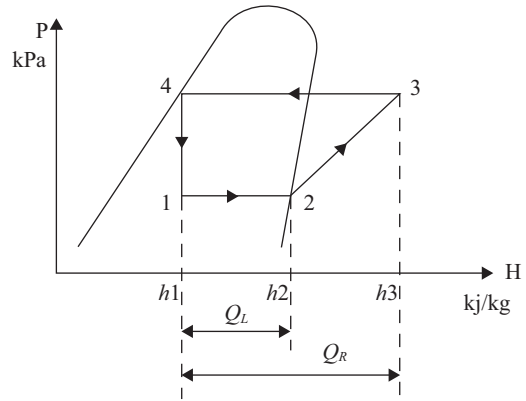

Fig. 2. A Mollier chart or P-H diagram.

where it experiences isenthalpic expansion. Its pressure rapidly decreases, causing part of the liquid to evaporate. The abrupt expansion of refrigerant facilitates evaporation.

- iv) *Evaporator*: The mixture of vapor and liquid at a low pressure and temperature enters the evaporator. The mixture absorbs heat from the surroundings and is vaporized to reach the saturated state. The resulting refrigerant returns to the compressor, and the cycle is repeated [17, 19].

### 2. Heat Pump Water Heater

Heat pumps are also known as reverse cycle air conditioners. The difference lies only in the range of the operating temperature. An evaporator absorbs thermal energy and air at low temperature. The refrigerant is then compressed to a high temperature in the compressor before being condensed to a low-temperature, high-pressure liquid in the condenser. The heat is released through the condenser, and water is warmed to provide hot water for users. The liquid refrigerant passes through an expansion valve to become a low-temperature, low-pressure liquid, and enters the evaporator to absorb heat at a constant pressure. The evaporation signals the completion of a cycle. Throughout this process, thermal energy from heat sources is continuously transferred to the cold water.

The power consumption of the compressor is an important technical and economic indicator, and the efficiency of a device is generally measured by the Coefficient Of Performance (COP), which is defined as:

$$COP = Q_H/W_E = (Q_L + W_E)/W_E = 1 + Q_L/W_E. \quad (1)$$

The heat for a heat pump heater is provided by the work done by the compressor, and the thermal energy from the air. Since the heat source is the air itself, insufficient sunlight does not affect the system, as it does in the solar case. The condenser is responsible for the expulsion of thermal energy. It can be seen from the Mollier chart in Fig. 2 that both the heat absorbed by the evaporator ( $Q_L$ ) and the work done by the compressor ( $W_E$ ) require expulsion by the condenser and,

therefore, the capacity of the latter  $Q_H$  must be larger than that of the evaporator  $Q_L$ . The expulsion capacity of the condenser is

$$\begin{aligned} Q_H &= Q_L + W_E \\ &= mr \times [(h_3 - h_2) + (h_2 - h_1)] \\ &= mr \times (h_3 - h_1). \end{aligned} \quad (2)$$

This can also be derived from the water volume and temperature difference. In water-cooled condensers, the heat released from the refrigerant is transferred to the water to raise its temperature, and the fundamental formula for heat conduction applies [14, 16]:

$$Q_H = m_w \times s \times \Delta T. \quad (3)$$

where  $m_w$  is the water rate (kg/s),  $s$  is the coefficient of conduction (J/kg °C), and  $\Delta T$  is the temperature difference (°C).

### III. FUZZY LOGIC CONTROLLER

Fuzzy logic was first proposed by Zadeh in 1965 to model the concept of ambiguity, particularly ambiguities in language. Sugeno adopted this theory to a number of research applications, creating the world-renowned Fuzzy Logic Controller (FLC) [3, 6, 9]. The main advantage of an FLC is its ability to deal with extremely complex mathematical models. In general, an FLC undergoes four steps (i) fuzzification, (ii) decision-making logic, (iii) fuzzy knowledge base, and (iv) defuzzification.

In this research, the FLC is applied to the unboiled water temperature as well as the bath water temperature. This data is made fuzzy, and it enters the fuzzy inference engine, as shown in Fig. 3. The fuzzy sets and membership functions used to quantify the temperature are described. In order to reduce errors, constant use is made of the triangular membership functions.

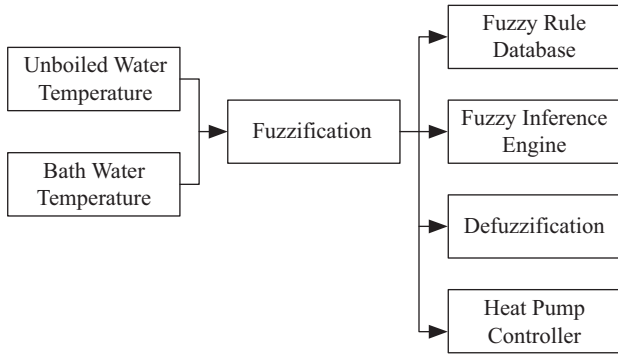

Fig. 3. Framework of the fuzzy logic controller.

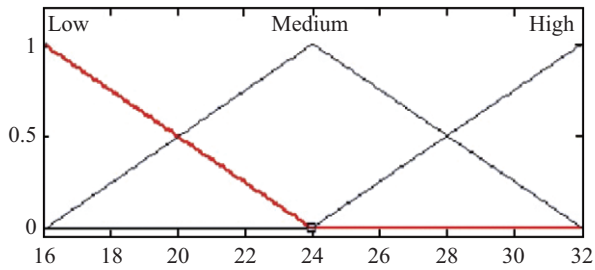

Fig. 4. Membership functions of the unboiled water temperature.

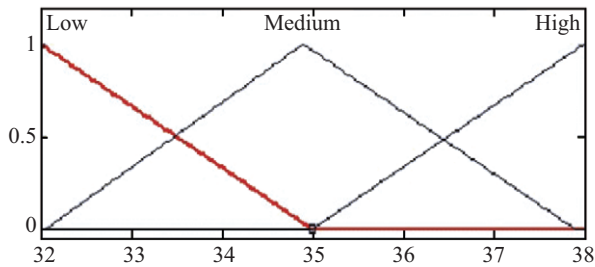

Fig. 5. Membership functions of the bath water temperature.

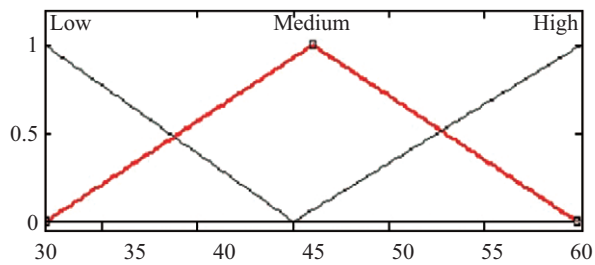

Fig. 6. Membership functions of the heat pump temperature.

Figs. 4, 5, and 6 show the membership functions for the front, rear, and consequent pieces, where the front is the input data and the rear is the heat pump control system. From the triangle representing the ownership function, the function value of each point is seen to lie between 0 and 1, corresponding to each input variable value, in which the horizontal

Table 1. Corresponding table of fuzzy rules.

		Bath water		
		Low	Medium	High
Unboiled water	Low	Medium	Large	Large
	Medium	Low	Medium	Medium
	High	Low	Low	Medium

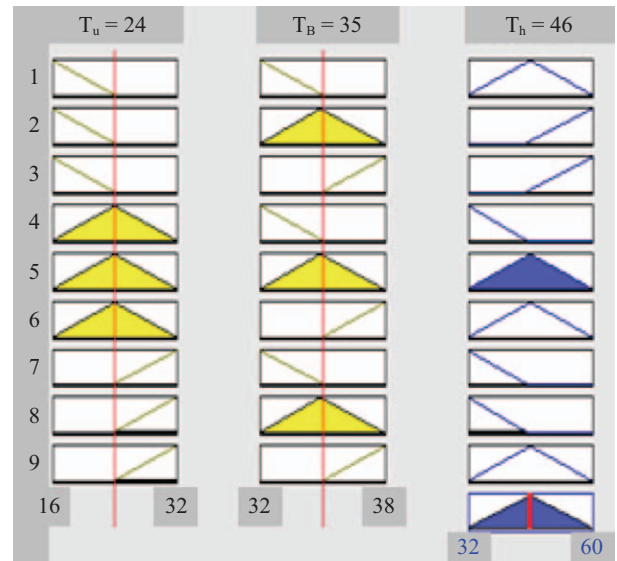

Fig. 7. Processes of the fuzzy logic controller.

coordinate for the input variable value is also known as the collection element. The ordinate is the size of the element, also known as the degree of ownership. Unboiled water temperature, bath water temperature, and the output value intensity can be divided into three states: high, medium, and low [1, 5, 6].

The FLC determines the form of the fuzzy rules that relate the water temperature and previous data, as shown in Table 1. The FLC is used with a given fuzzy inference engine that will find the minimum of a problem [9]. The inference engine's operation is shown in Fig. 7. It assumes that the intensity of the input value (24°C) of the unboiled water temperature triggers three rules. The one that is triggered by a high degree of intersection of fuzzy sets is truncated (yellow area). The heights of the truncated portion are 4, 5, and 6 for the first rule of fitness. The bath water temperature value (35°C) triggers six rules. The one that is triggered by a high degree of intersection of fuzzy sets is truncated (yellow area). The heights of the truncated portion, given by the first rule, are 1, 2, 4, 5, 7, and 8. The two variables fit to take the intersection, and then take the output fuzzy set at the Y intersection. The fuzzy set of the final is the union of the most fuzzy sets.

The following equations are used to compute the algorithms, with input values  $T_u$  and  $T_b$ ; the fitness of the front and rear pieces are denoted by  $W$  and  $B$ , respectively [2, 11]:

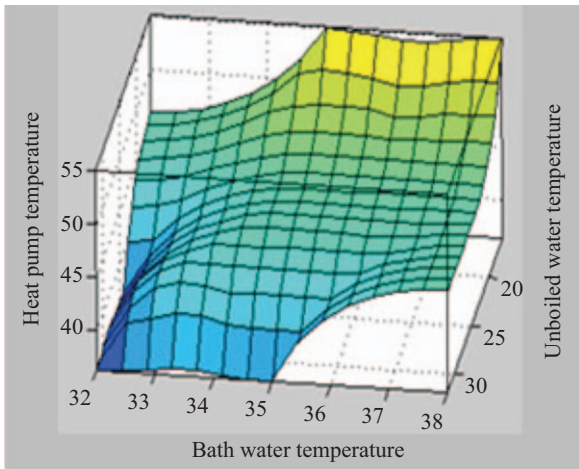

Fig. 8. The output of the FLC.

$$W_i = \text{Min}\{\max[\min(T_{ui}, T_u'), \max[\min(T_{bi}, T_b')]]\}, \quad (4)$$

$$B'_i = \min(W_i, \mu_{B'_i}(y)). \quad (5)$$

where  $i$  is the rule number,  $T_u'$  and  $T_u'$  are the inputs and  $\mu$  is the output. For the entire rule set:

$$B = \text{Max}_{i=1}^r B'_i, \quad (6)$$

where  $r$  is the number of rules triggered. The MATLAB Fuzzy Logic Toolbox was used to establish the FLC output, as shown in Fig. 8.

#### IV. INTELLIGENT HEAT PUMP HEATER WITH FUZZY LOGIC CONTROLLER

##### 1. Introduction to the Microcontroller

The microcontroller is an essential component of a micro-computer system. The central processing unit, memory unit, input/output unit, pulse generation unit, and other peripheral devices are placed on a single chip to produce a simple microcomputer system. In this study, the development is primarily based on the HT46R23 chip, which is shown in Fig. 9. The main functions are described using simplified block diagrams in Fig. 10 [8]. The HT46R23 microcontroller system includes 4096 (000H-FFFH) × 15 bits of program space allocated for the storage of command codes. The CPU is utilized to obtain program commands and to execute them. The CPU can only read the content and cannot write anything into the memory space. There are two groups of pulse oscillator circuits in HT46R23: the crystal oscillator and the RC oscillator. The crystal oscillator circuit can generate a pulse with a very stable frequency when a quartz oscillator is attached externally.

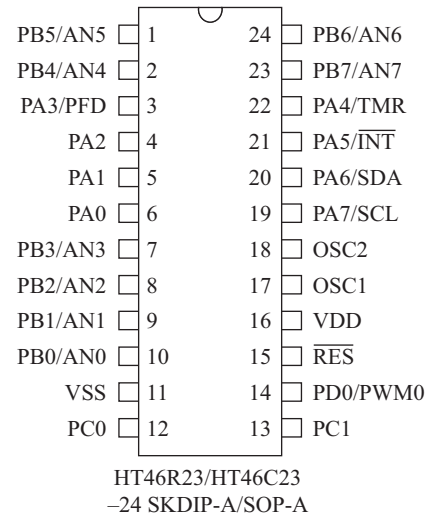

Fig. 9. Appearance of the HT46R23 chip.

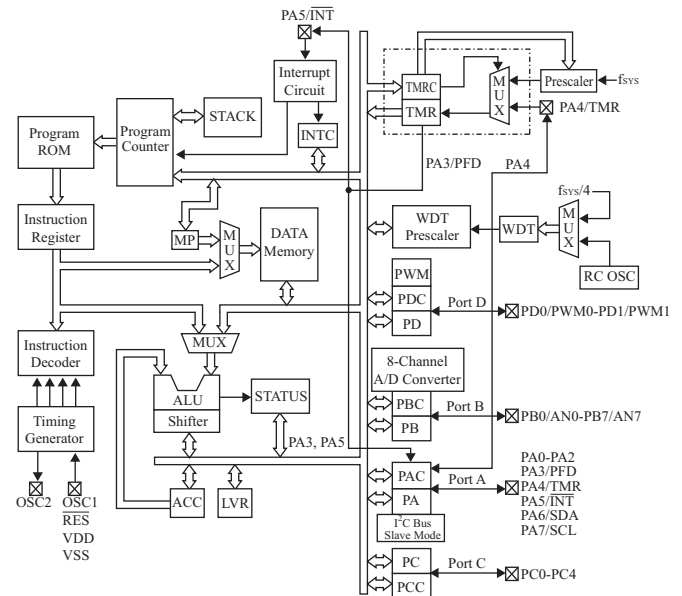

Fig. 10. Internal structure of HT46R23.

##### 2. Control System Planning

The proposed control system employs a microcontroller to record the temperatures of the cold water and the bath water in Microsoft Excel through RS-232 using the VISA serial fuzzy value obtained from MATLAB. This value is passed to the microcontroller via RS-232, and is used as the heating temperature in the fuzzy controller. Fig. 11 shows a flowchart for the heat pump heater with the FLC. The unboiled water and the bath water temperatures are converted to digital signals using the A/D inverter in the microcontroller and transferred to a workstation via RS-232. The “LabVIEW” control software is used as the operating interface. LabVIEW obtains the water temperatures, while the heating temperature is calculated using fuzzy equations in MATLAB.

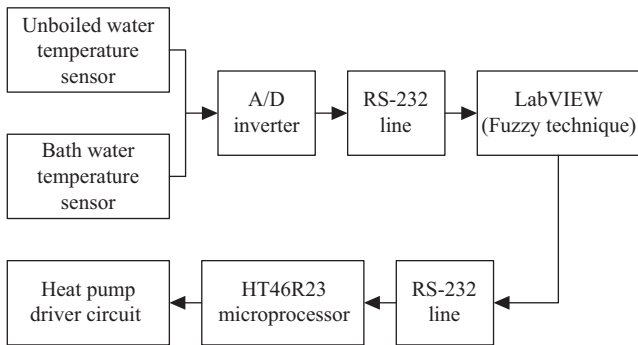

Fig. 11. Flowchart for the heat pump heater with a fuzzy logic controller.

### 3. Temperature Display and Circuit Design

The temperature sensor circuit is a common application circuit. The AD590 is a thermometer that can measure temperatures in the range 0-150°C. Its output current is proportional to the ambient temperature. The current coefficient is 1  $\mu\text{A}/\text{K}$ , which means that the current increases 1  $\mu\text{A}$  with a 1 K increase in temperature. Three groups of temperature sensors are used in this study. The use of AD590 will result in a relatively large sensor system circuit. Therefore, the HT46R23 microcontroller is used. The PB.0-PB.7 pins can be used as general input/output pins as well as A/D pins. Unlike AD590, which requires multiple types of active and passive components, the microcontroller only requires a single thermistor and a precision resistor in a temperature sensor circuit. The temperature-sensing component in this study is a thermistor with a resistance of 10 k $\Omega$ . At 25°C, the resistance is 10 k $\Omega$ . The temperature can be obtained by measuring its resistance and using its characteristic curve.

## V. RESULTS AND DISCUSSION

The intelligent heat pump water heater system proposed in this paper utilizes a fuzzy logic controller to develop the heating algorithm. To verify its feasibility, energy efficiency, and other improvements in performance, it is compared with normal heaters. The hardware of the developed system is shown in Fig. 12.

The thermal energy for the heat pump water heater comes from both the input electrical energy from the compressor and the atmosphere. As the heat in the atmosphere is inexhaustible, heat pump technology can be viewed as an energy amplifier. To test the heating function of the heat pump, 50 liters of water are poured into the water storage bucket. The heat pump water heater relies on the refrigerant releasing thermal energy to heat up the water. Fig. 13 shows the condenser in the water bucket.

The heat pump heats up the water by the release of heat from the condenser. The condenser does not run on electricity or gas, so there are no electrical safety and carbon monoxide poisoning concerns. It is a safe and highly efficient heating device. Measurements taken when heating at a room temperature of 24°C are recorded in Table 2. It takes the heat

Table 2. Heating temperature and power consumption of the heat pump water heater.

Time (min)	Water temperature	Operating voltage of compressor (V)	Operating current of compressor (A)	Input power of compressor (W)
0	20°C	220	4.2	924
5	24°C	220	4.4	968
10	28°C	220	4.6	1012
15	32°C	220	4.8	1056
20	37°C	220	4.9	1078
25	41°C	220	5	1100
30	45°C	220	5.1	1122
35	49°C	220	5.2	1144
36	50°C	220	5.3	1166



Fig. 12. Hardware for the intelligent heat pump heater.



Fig. 13. The heat pump water heater.

pump water heater 46 minutes (2760 seconds) to raise the temperature of 50 liters of water from 20°C to 50°C. The COP for the device is found like so:

**Table 3. Comparison of temperature increases/decreases for the heat pump heater.**

Items	Value			
	55-52	55-49	55-46	55-43
Water temperature	55-52	55-49	55-46	55-43
Time of temperature increase (min)	50	160	320	500
Time of temperature decrease (sec)	300	600	860	1,160
Average power of heating (J)	415,800	798,600	1,107,680	1,467,400
Operation time within 24 hours	26	8.5	4.3	2.8
Total power within 24 hours	10.8 MJ = 3 kw/h	6.79 MJ = 1.9 kw/h	4.76 MJ = 1.3 kw/h	4.11 MJ = 1.1 kw/h

$$H1 = 50,000 \times 30 = 1,500,000 \text{ cal}$$

$$H2 = 1000 \times 0.24 \times 2760 = 662,400 \text{ cal}$$

$$\text{COP} = 1,500,000/662,400 = 2.26,$$

where H1 is the thermal energy produced, and H2 is the input power for the 1 kW compressor.

The initial water temperature is 20°C. The recording terminates when the temperature reaches 50°C. The initial power consumption of the compressor is 924 W, and it increases continuously, reaching 1166 W at the end of the experiment.

The pressure of the refrigerant increases with increasing temperature during the heating process and the power of the compressor also increases. Therefore, adjusting the temperature for the heat pump can lead to a clear saving of electrical energy. Water is normally heated to 55°C and maintained to within 3°C of this value, regardless of the habit of hot water usage and ambient temperature, thus ensuring sufficient hot water supply at all times. Heating water from 52°C to 55°C using a heat pump heater takes 300 s. The average power consumption of the compressor is 1386 W. Therefore, the total energy spent in one heating cycle is  $1386 \text{ W} \times 300 \text{ s} = 415,800 \text{ J}$ . It takes 50 min for the water temperature to drop from 55°C to 52°C. Adding the 300 s (5 min), it means the compressor must operate  $(24 \times 60) / 55 = 26$  times in 24 h. The total electrical energy consumption is:

$$H = 415,800 \times 26 = 10,810,800 \text{ J} = 3 \text{ kWh.}$$

This is the energy consumption of a traditional heat pump heater. Heat pump heaters with fuzzy control have varying heating temperatures under different environments and water use habits. For example, when unheated water is at 19°C and bath water is set to 37°C, the heating temperature calculated by the fuzzy controller is 49°C. This means that after the water is initially heated to 55°C, it will only be heated up again when its temperature drops to 49°C. The energy consumption in this case is calculated as:

- The energy consumed in raising the water temperature from 49°C to 55°C is  $1331 \text{ W} \times 600 \text{ s} = 798,600 \text{ J}$ .
- It takes 160 min for the temperature to drop from 55°C to 49°C. Therefore, in 24 hours, the compressor operates 8.5

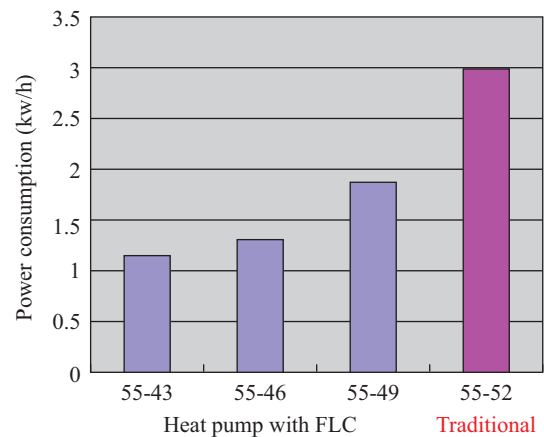

**Fig. 14. Comparison of the power consumption for a heat pump heater and a traditional heater.**

times and consumes  $798,600 \text{ J} \times 8.5 = 76,788,100 \text{ J} = 1.89 \text{ kWh}$ .

The energy consumption for various temperatures is tabulated in Table 3. A comparison of the power consumption for a heat pump with fuzzy logic and a traditional heat pump is presented in Fig. 14. It can be seen that the former achieves superior energy efficiency by adopting an appropriate heating algorithm.

## VI. CONCLUSION

In this paper, an intelligent heat pump heater was proposed. The heater derived its heating algorithm from a fuzzy logic controller. Test results showed that the use of the proposed heater resulted in a reduction in the consumed energy compared to traditional water heaters. In Table 4, the power consumptions of various heating devices are given, among which the heat pump heater saves 60% more power compared to electric heaters. In addition, the heat pump heater with fuzzy control yielded an optimum heating temperature by taking into consideration parameters including the unheated water temperature and bath water temperature. This further improved the efficiency of the heater. Moreover, the associated cost of energy sources also requires consideration, especially in view of the recent oil price increases and rising cost of natural gas.



**Table 4. The energy costs of different heating devices (assuming 100 KJ is required to heat 5 L of water from 30°C to 50°C).**

Devices	Heat required	Heat per unit energy source	Energy consumption	Unit price	Costs	Energy saving in comparison with electric heater
Electric heater	100 KJ	≈ 774 kJ/kWh	= 0.1292 kWh	× 2.6 yuan/kWh	= 0.3359 yuan	—
Gas heater	100 KJ	≈ 4938 kJ/m <sup>3</sup>	= 0.0203 m <sup>3</sup>	× 12.8 yuan/m <sup>3</sup>	= 0.2598 yuan	23%
Heat pump heater (COP 2.26)	100 KJ	≈ 1957 kJ/kWh	= 0.0511 kWh	× 2.6 yuan/kWh	= 0.1328 yuan	60%

It can be seen from Table 4 that the cost of a gas heater is clearly higher compared to heat pump heaters.

### ACKNOWLEDGMENTS

The author would like to thank the National Science Council of the Republic of China, Taiwan, for financially supporting the research under Contract No. NSC 102-2221-E-269-018.

### REFERENCES

- Alcalá, R., Benítez, J. M., Casillas, J., Cordon, O., and Pérez, R., "Fuzzy control of HVAC systems optimized by genetic algorithms," *Applied Intelligence*, Vol. 18, pp. 155-177 (2003).
- Alcalá, R., Casillas, J., Cordon, O., González, A., and Herrera, F., "A genetic rule weighting and selection process for fuzzy control of heating, ventilating and air conditioning systems," *Engineering Applications of Artificial Intelligence*, Vol. 18, pp. 279-296 (2005).
- Arzu, S. S., Bayram, K., and Ulaş, K., "Optimization of heat pump using fuzzy logic and genetic algorithm," *Heat and Mass Transfer*, Vol. 47, pp. 1553-1560 (2011).
- Cho, C. W., Lee, H. S., Won, J. P., and Lee, M. Y., "Measurement and evaluation of heating performance of heat pump systems using wasted heat from electric devices for an electric bus," *Energies*, Vol. 5, pp. 658-669 (2012).
- Cho, E., Ha, M. Y., Chang, S. D., and Hwang, Y. J., "Variable fuzzy control for heat pump operation," *Journal of Mechanical Science and Technology*, Vol. 25, No. 1, pp. 201-208 (2011).
- Choi, J. W., Lee, G. B., and Kim, M. S., "Capacity control of a heat pump system applying a fuzzy control method," *Applied Thermal Engineering*, Vol. 31, pp. 322-339 (2011).
- Christopher, J. K. and Evanthia, A. N., "Life cycle environmental impact assessment of a solar water heater," *Journal of Cleaner Production*, Vol. 37, pp. 154-161 (2012).
- Holtek Semiconductor Inc., "HT46R23," *Datasheets for Electronics Components*, Taipei city, Taiwan (2004).
- Hsieh, G. C., Chen, L. R., and Huang, K. S., "Fuzzy-controlled Li-Ion battery charge system with active state-of-charge controller," *IEEE Transaction on Industrial Electronics*, Vol. 48, pp. 585-593 (2001).
- Ladd, G. O. and Harrison, J. L., "Electric water heating for single family residences: group load research and analysis," *EPRI Report*, EA-4006 (1985).
- Lin, C. S., Lin, M. L., Liou, S. R., Shei, H. J., and Su, W. P., "Development and applications of a fuzzy controller for a forced circulation solar water heater system," *Journal of Scientific & Industrial Research*, Vol. 69, pp. 537-542 (2010).
- Lin, W. M., Chang, K. C., Liu, Y. M., and Chuang, K. M., "Field surveys of non-residential solar water heating systems in taiwan," *Energies*, Vol. 5, pp. 258-269 (2012).
- Masuta, T. and Yokoyama, A., "Supplementary load frequency control by use of a number of both electric vehicles and heat pump water heaters," *IEEE Transaction on Smart Grid*, Vol. 3, pp. 1253-1262 (2012).
- Meyer, J. P., "A review of domestic hot water consumption in South Africa," *R&D Journal*, Vol. 16, pp. 55-61 (2000).
- Ndiaye, D. and Bernier, M., "Transient model of a geothermal heat pump in cycling conditions – Part B: Experimental validation and results," *International Journal of Refrigeration*, Vol. 35, No. 8, pp. 2051-2358 (2012).
- Rankin, R. and Rousseau, P. G., "Sanitary hot water consumption patterns in commercial and industrial sectors in South Africa: Impact on heating system design," *Energy Conversion and Management*, Vol. 47, pp. 687-701 (2006).
- Ravi, N., Thota, S. R., and Talari, J. P., "Performance evaluation of high speed compressors for high speed multipliers," *Serbian Journal of Electrical Engineering*, Vol. 8, No. 3, pp. 293-306 (2011).
- Renatio, M. L. and Giovanni, A. L., "Comparison of heat recovery system in public indoor swimming pool," *Applied Thermal Engineering*, Vol. 16, No. 7, pp. 561-570 (1996).
- Zheng, J. T., Wang, X. F., Wang, W., and Sun, Y. M., "Applied study of on-line evaluation for operating performance of 102J turbo-compressor sets based on thermodynamic parameter diagnosis," *Challenges of Power Engineering and Environment*, Vol. 1, pp. 529-532 (2007).