



DEVELOPMENT OF A FLOW-DRIVEN, SELF-ROTATING TANK DEPOSIT REMOVER FOR GROUPEL NURSERIES

Chyng-Hwa Liou

Department of Aquaculture, National Taiwan Ocean University, Keelung, Taiwan, R.O.C.

Chung-Lee Lee

Department of Aquaculture, National Taiwan Ocean University, Keelung, Taiwan, R.O.C.

Jyh-Nain Pai

Freshwater Aquaculture Research Center, Fisheries Research Institute, Council of Agriculture, The Executive Yuan, Taiwan, R.O.C.

Yuan-Nan Chu

*Department of Bio-Industrial Mechatronics Engineering, National Taiwan University, Taipei, Taiwan, R.O.C.,
ynchu@ntu.edu.tw*

Follow this and additional works at: <https://jmstt.ntou.edu.tw/journal>



Part of the [Aquaculture and Fisheries Commons](#)

Recommended Citation

Liou, Chyng-Hwa; Lee, Chung-Lee; Pai, Jyh-Nain; and Chu, Yuan-Nan (2018) "DEVELOPMENT OF A FLOW-DRIVEN, SELF-ROTATING TANK DEPOSIT REMOVER FOR GROUPEL NURSERIES," *Journal of Marine Science and Technology*. Vol. 26: Iss. 3, Article 15.

DOI: DOI: 10.6119/JMST.201806_26(3).0015

Available at: <https://jmstt.ntou.edu.tw/journal/vol26/iss3/15>

This Research Article is brought to you for free and open access by Journal of Marine Science and Technology. It has been accepted for inclusion in Journal of Marine Science and Technology by an authorized editor of Journal of Marine Science and Technology.

DEVELOPMENT OF A FLOW-DRIVEN, SELF-ROTATING TANK DEPOSIT REMOVER FOR GROUPEL NURSERIES

Chyng-Hwa Liou¹, Chung-Lee Lee¹, Jyh-Nain Pai², and Yuan-Nan Chu³

Key words: deposit remover, recirculating aquaculture systems, grouper nursery.

ABSTRACT

Tank hygiene is an essential aspect for successful fingerling production but can involve substantial workload to maintain. The purpose of this research is to develop and test a new version of a flow-driven, self-rotating tank deposit remover to automatically and quickly remove the deposit for grouper nurseries. The deposit remover has a suction tube lying on the bottom of the tank. Water flowing through the suction tube drives a propeller to rotate the tube while sucking up the solids on the bottom. Previous versions of the deposit remover suffer from incomplete solid removal and a long operating time. An integrated nozzle/scrapper assembly is introduced to improve the water inlet of the suction tube. A new gear box is designed to reduce the footprint by one-half and to align the input and output shafts for better balance. Modifications are made to the pivoting pipe elbow to achieve a uniform spacing between the suction tube and tank bottom and to eliminate solid accumulation surrounding the pipe. Optimum configurations of the propeller and the scrapper are determined by experiment. The results show that the new deposit remover could remove more than 93% of size 0 and 3 feeds in one turn and could remove all the size 0 feed in 4.3 min and size 3 feed in 2.6 min at a flow rate of 1.77 L/sec. The removal speed is five times faster than the previous version making it a practical tool for the automatic bottom cleaning of grouper nursery tanks.

I. INTRODUCTION

Grouper production is currently the most important marine fish production in Taiwan's aquaculture (Fisheries Agency, 2016). At nineteen thousand tons per year and a value of 5.3 billion NT, it ranks number two in the world grouper production. The grouper production in Taiwan is divided into brood stock, hatchery, nursery, and grow out stages with many small farms each focusing on one stage forming a unique infrastructure of grouper production (Yang, 2017). The production of juvenile groupers from the larvae to the fingerling stage is a critical period of grouper production because of viral diseases (Kokawa et al., 2008; Ma et al., 2012). Mass mortality has prompted many farmers to use indoor recirculating aquaculture systems (RAS) to grow the fingerlings (Lee, 2012). However, in the indoor high density production environment, cannibalism becomes a problem (Hseu, 2004). To mitigate cannibalism, the grouper fingerlings are commonly cultured in small floating cages in the culture tanks to separate the fish by size (Sheen et al., 2014). These floating cages would interfere with the circular flow pattern in the tank to eliminate secondary flow, so that the solid deposits could not move to the center drain of the tank and instead would scatter over the bottom of the tank. The accumulation of deposits encourages bacterial and protozoa proliferation causing fish diseases and reduced survival rate (Chen, 2011).

Cripps and Bergheim (2000) reported that quick removal of the particulate material could effectively reduce organic matters. To maintain tank hygiene for successful fingerling production, daily cleaning to remove the settled solids is necessary (Müller-Belecke et al., 2015) but would cost much labor and water resource in grouper nursery production. The development of automatic cage-bottom solid collectors and self-rotating deposit removers in this laboratory provides a solution to this problem (Yanz, 2010; Chen, 2011). It has been demonstrated that effective removal of the settled solids in the tanks by the automatic devices could reduce not only ammonia concentration but also bacterial count, thereby improving the survival of the fingerlings (Chen, 2011).

The development of the self-rotating deposit remover in this lab has lasted for more than eight years and has gone through many versions (Chen, 2011; Lin, 2013; Chen, 2015). It is envi-

Paper submitted 01/30/18; revised 02/13/18; accepted 02/21/18. Author for correspondence: Yuan-Nan Chu (e-mail: ynchu@ntu.edu.tw).

¹Department of Aquaculture, National Taiwan Ocean University, Keelung, Taiwan, R.O.C.

²Freshwater Aquaculture Research Center, Fisheries Research Institute, Council of Agriculture, The Executive Yuan, Taiwan, R.O.C.

³Department of Bio-Industrial Mechatronics Engineering, National Taiwan University, Taipei, Taiwan, R.O.C.

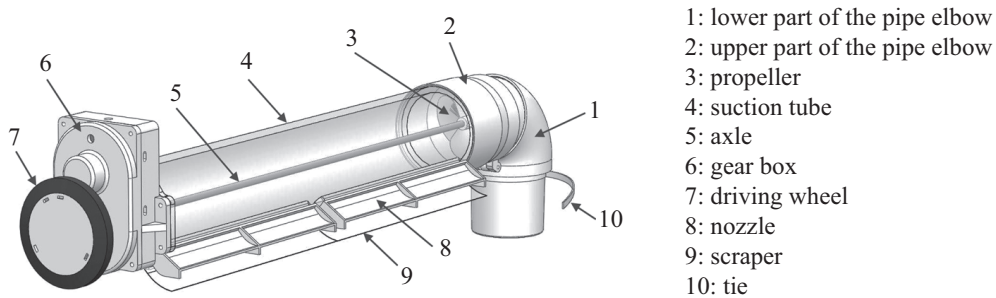

Fig. 1. The deposit remover. The figure shows only two sets of nozzles and scrapers for convenience of illustration, but the actual deposit remover has four sets of nozzles and scrapers and a twice longer suction tube.

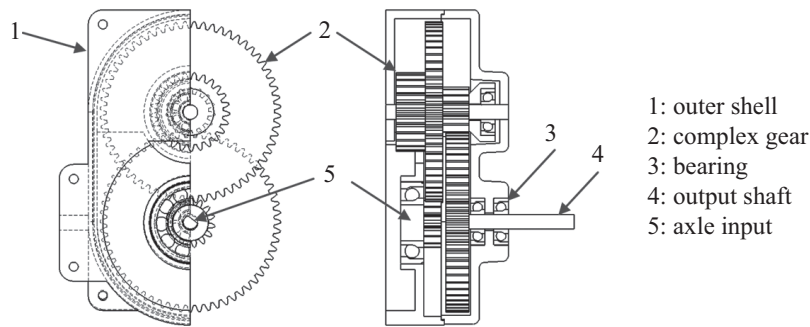

Fig. 2. The gear box.

sioned that the deposit remover can become a vital tool in grouper nurseries. However, the previous versions still had problems mainly in the speed and completeness of deposit removal. This research aims to solve these problems. The purpose of this research is to redesign and develop a new self-rotating deposit remover not only to improve the efficiency of deposit removal but also to increase the manufacturability of the device toward creating a commercial product to be available to the grouper industry.

II. MATERIAL AND METHODS

1. The Deposit Remover

The flow-driven, self-rotating deposit remover developed in this research is shown in Fig. 1. It is composed of a transparent acrylic suction tube (4), a stainless steel axle (5) within the tube, a set of propellers (3) on the axle, a gear box (6) at the outer end of the tube, a driving wheel (7) on the output shaft of the gear box, a flexible pipe elbow (1 and 2) at the center end of the suction tube, a tie (10) on the elbow and 4 sets of long narrow nozzles (8) and scrapers (9) inserted into the lower front slots of the suction tube.

In operation, the lower part of the pipe elbow (1) is to be loosely inserted into the draining hole of the culture tank as both a pivot and a water conduit so that the deposit remover could rotate about the draining hole while discharging water. The scraper is pressed against the bottom of the tank by the own weight of the deposit remover. The narrow space between the nozzle and

the scraper forms a long narrow water inlet just above the bottom surface of the tank. By letting water to flow out of the tank, the water in the tank would go through the water inlet and flow in the suction tube all the way to the center end to drive the propellers and the axle to rotate. The rotation speed is reduced by the gear box then drives the wheel to rotate the suction tube. Therefore the deposit remover would rotate about the draining hole while sucking up the deposits from the bottom. Since the energy is derived from water, there is no need for electricity to run the deposit remover.

The gear box is shown in Fig. 2. There are two sets of compound gears coupled together to form a reverted gear train where the input shaft is in line with the output shaft. This design would improve the balance of the deposit remover in operation. The compound gear train has two 5 to 1 speed reductions so that the final reduction ratio of the gear box is 1/25. The parts of the gear box are all made by 3D printing using either PLA or ABS. Plastic bearings with glass balls are used to support the gears on their axles. The footprint of the gear box is 70 × 47 mm, about half of the previous version.

The driving wheel is made from a 3D printed hub covered with a piece of V-belt to improve friction to the tank bottom. The diameter of the driving wheel is approximately 7.6 cm. The suction tube is 800 mm long and has an inside diameter of 60 mm and a wall thickness of 3 mm. The diameter of the stainless steel axle is 5 mm. The propeller is plastic, 52 mm in diameter, having three blades.

The flexible pipe elbow consists of an upper part (2) and a

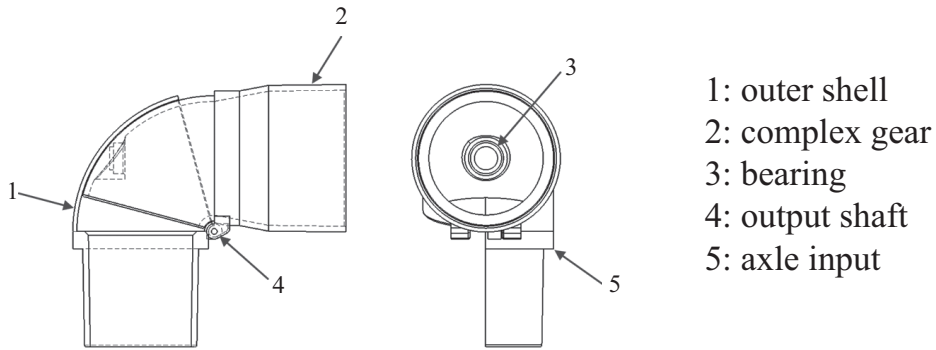

Fig. 3. The flexible pipe elbow.

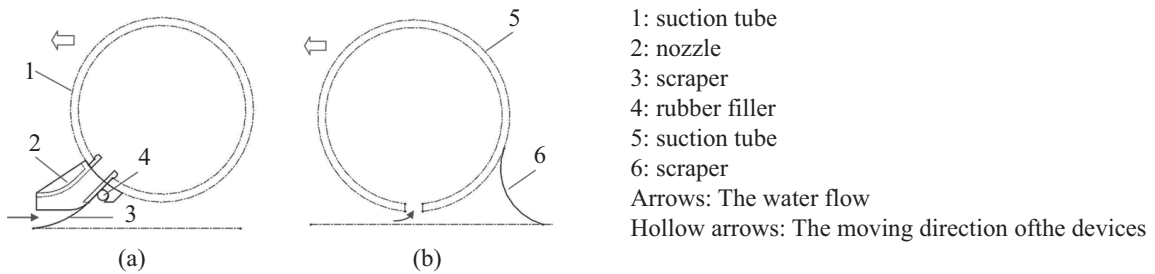

Fig. 4. (a) New design of the integrated nozzle/scrapper. (b) Previous design.

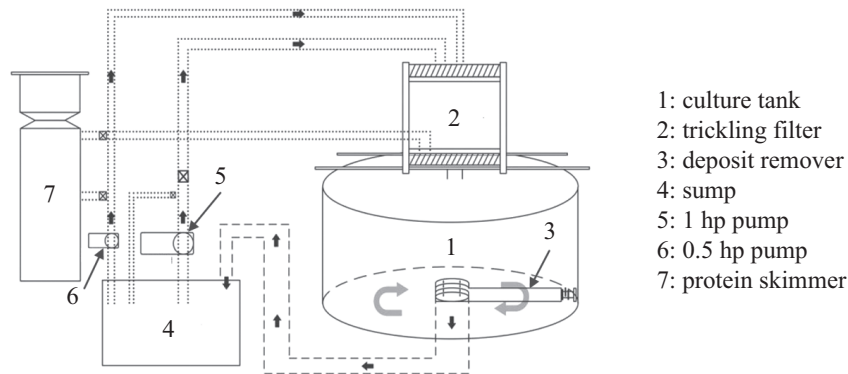

Fig. 5. Experiment setup.

lower part (1) connecting together at a hinge (4) as shown in Fig. 3. The center end of the suction tube is fixed to the inside of the upper part of the pipe elbow. There is a bearing holder (3) inside the upper part to support the propeller axle. When the lower part is inserted into the draining hole of the tank, the upper part can swing vertically from $+15^\circ$ to -60° . This allows the suction tube to move up and down to follow the topology of the tank bottom. The upper part and the lower part overlaps with a close fit so that when the upper part swings there would be little leakage of water. Thanks to the flexible pipe elbow, the deposit remover could fit any round tank whether or not there is a bottom slope. When the lower part of the pipe elbow is inserted into the draining hole, the bottom shoulder (5) would prevent the lower part from going further down into the drain-

ing hole and get stuck. A plastic tie is fixed to the lower part against the bottom shoulder (5) with a long loose end extending outwards. As the pipe elbow rotates, the loose end of the tie would brush the nearby deposit away to prevent their accumulation around the pipe elbow.

The nozzles (2) are mounted on the front side of the suction tube (1) at a downward inclination angle of 45 degrees (Fig. 4(a)). The nozzles are 190 mm long and are made from 3D printing. The nozzles are designed as separate parts that could be quickly assembled to the suction tube by inserting into the slots on the suction tube. This would make the deposit remover much easier to manufacture since the suction tube could be manufactured from off the shelf tubing to reduce the cost. The water passage width on the nozzle is 7 mm, large enough for the grouper

feeds to pass. The scraper (3) extends forward from the bottom of the nozzles to guide the flow into the nozzles. It is held in place by squeezing a piece of round thick rubber filler (4) into the narrow pinching slot. The scraper is made from 0.18 mm thick plastic sheets and is designed as a consumable part that needs replacement after a certain period.

2. The Experiment Setup

Tests of the deposit remover are conducted in a recirculating aquaculture system simulating the grouper nursery environment (Fig. 5). The deposit remover is installed in a 2.5 ton round culture tank. The outflow from the tank flows by gravity to a sump. A thick layer of filtering cloth is placed on top of the sump to separate the solids from the water. A 1 hp pump moves water from the sump to a trickling filter on top of the culture tank. The flow rate to the trickling filter is controlled by a side valve. A second 0.5 hp pump moves water from the sump to a protein skimmer to remove fine particles in the water. The outflow from the protein skimmer also goes to the trickling filter. The water from the trickling filter falls directly to the culture tank to complete recirculation. Three floating cages are placed in the tank to simulate actual culture condition.

3. The Experiments

Several experiments are conducted to find the optimal design configuration of the deposit remover. Then the deposit remover is tested for the performance of solid removal for different feed sizes and flow rates. The experiments use commercial grouper feeds (Grobest, Taiwan) as the test material. Two sizes of the feed, size 0 (1.7 mm in diameter and 1.4 mm in thickness) and size 3 (4.6 mm in diameter and 3.4 mm in thickness) are used. The flow rate is determined by collecting water with a 14.4 L bucket at the sump. Each measurement is repeated for 10 times.

The test results are analyzed using the SPSS software (IBM SPSS Statistics 20.0, SPSS Inc., Chicago). ANOVA is performed to test the significance of variance. Duncan's new multiple range test is used if the difference is significant (Puri and Mullen, 1980).

1) Effect of Propeller Position

The propellers are positioned in the upper part of the flexible pipe elbow. Since the flow pattern is very complex and dynamic here, the exact position of the propellers affects the amount of energy that could be transferred from water to the propellers. An experiment is conducted to determine the best position of the propellers. Three propellers are placed in series at fixed angle with no space in between. The effect of the distance between the first propeller to the bearing holder of the upper part of the pipe elbow is tested at a flow rate of 1.77 L/sec. Three distances, 2.1, 3.9, and 5.7 cm are tested to determine the time for the deposit remover to finish one turn. Due to the physical limitation of the propellers, the smallest distance that can be reasonably tested without causing interference between the propellers and the pipe elbow is 2.1 cm.

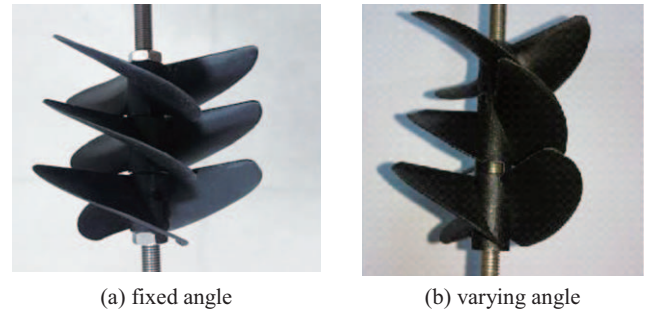

Fig. 6. Relative angle conditions.

2) Effects of Propeller Quantity and Relative Angle

Another experiment is conducted to determine the effects of the quantity and relative angle of the propellers on the time for the deposit remover to finish one turn at a flow rate of 1.77 L/sec. The number of propellers varies from one to four. The propellers are placed at either fixed angle, as in Fig. 6(a), or varying angle, as in Fig. 6(b). The varying angle is like extending the blades of the propellers to form a long propeller.

3) Effect of Scraper Length

The effect of the length of the scraper is tested at a flow rate of 1.77 L/sec. A hundred grams of grouper feed is spread evenly into the tank. Ten different scraper lengths from 2 cm to 6.5 cm are tested for the time required to remove all the feed.

4) Effects of Flow Rate and Feed Size

Since the deposit remover rotates by the energy of water, the flow rate of water certainly would affect its rotation speed which determines how fast the deposit remover could sweep a complete cycle. Four flow rates, 1.31, 1.49, 1.77, and 1.86 L/sec, are tested to determine the time required for the deposit remover to rotate one complete turn.

A second test is then conducted to determine the time required to remove 100 gram of different sized feed at the four flow rates.

A third test is conducted to determine the removal rate by each turn of the deposit remover at different flow rates. During each turn, the removed feed is collected by a 150 mesh plankton net. The collected feed is dried in an oven and weighed.

The removal rate is calculated as below.

$$\text{Removal rate (\%)} = \frac{\text{dry weight of the feed removed}}{\text{total dry weight of feed removed}} \times 100 \quad (1)$$

III. RESULTS

1. Effect of Propeller Position

Propeller position significantly affects the time required for the deposit remover to rotate one turn (Fig. 7). The difference in rotation time due to propeller position is significant as shown by the superscripts in the figure. The rotation time is smallest when the propellers are placed at a distance of 2.1 cm from the

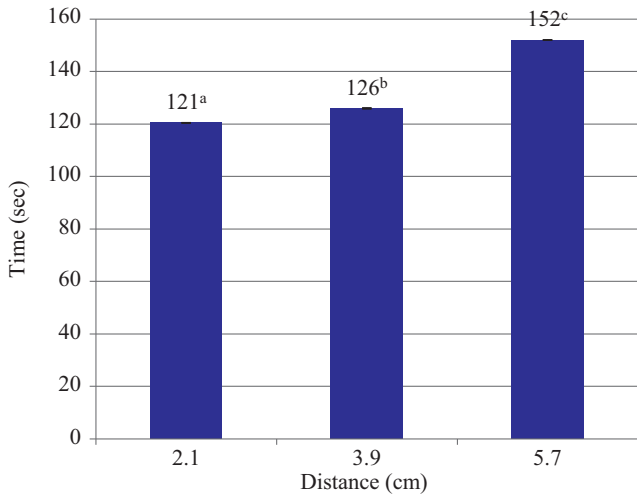

Fig. 7. Effect of propeller position on the time required for the deposit remover to rotate one turn.

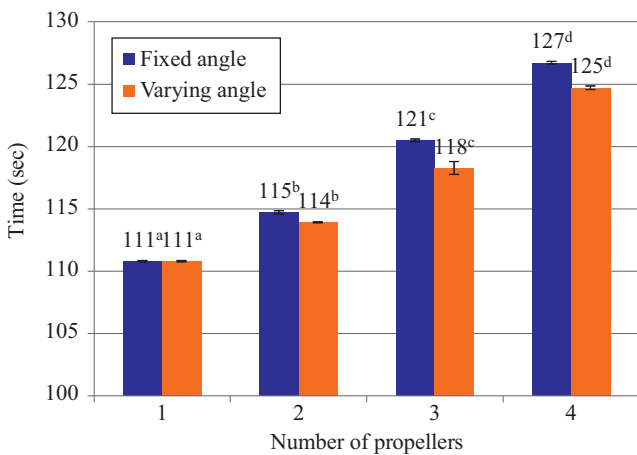

Fig. 8. Effects of the number of propellers and their relative angle on the time required to finish one turn.

bearing holder of the pipe elbow. It takes 121 sec to finish one turn, or 30 turns in an hour. The rotation time is largest when the propellers are placed at a distance of 5.7 cm, taking 152 sec to finish one turn, or 23.7 turns in an hour. The change in propeller position from 2.1 cm to 5.7 cm results in an increase in rotating time of about 25.6%.

2. Effects of Propeller Quantity and Relative Angle

The number of propellers significantly affects the rotation speed, as shown in Fig. 8. The more propellers, the longer the time needed for the deposit remover to finish one turn. It takes only 111 seconds to finish one turn when there is only one pro-PELLER. In contrast, it takes 125 and 127 seconds to finish one turn when four propellers are used.

When the number of propellers is larger than one, the relative angle of consecutive propellers slightly affects the time required for the deposit remover to finish one turn. Propellers at fixed

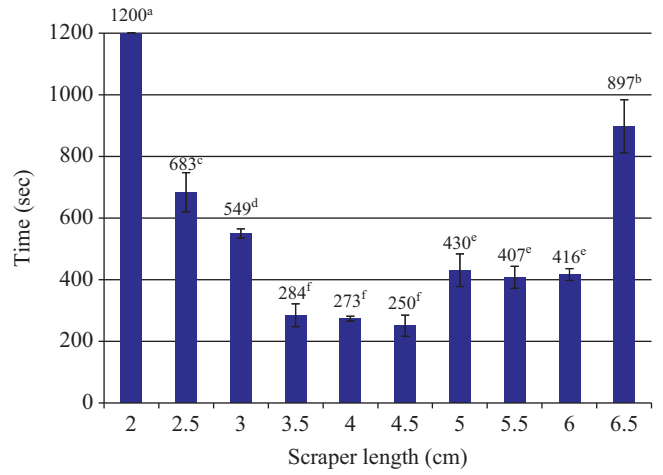

Fig. 9. Effect of scraper length on the time required to remove all the size 0 feed.

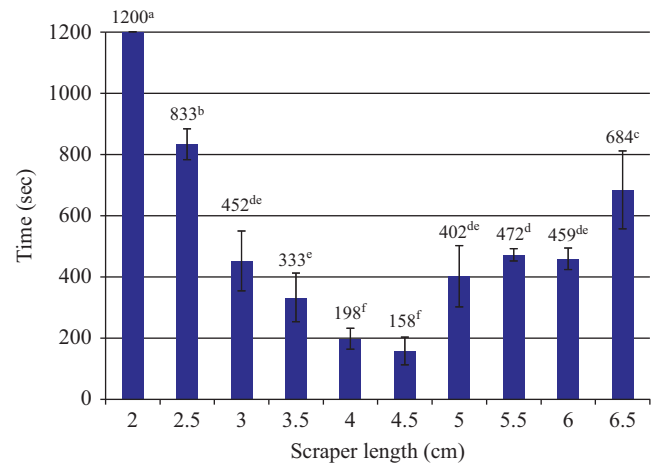

Fig. 10. Effect of scraper length on the time required to remove all the size 3 feed.

angle would result in a slower rotation speed than propellers arranged with consecutively changing angles. However the effect of relative angle is smaller than the effect of propeller quantity. Since using only one propeller is clearly the best choice to increase rotation speed, the influence of relative angle is ignored. The tests that follow then use only one propeller at a distance of 2.1 cm from the bearing holder of the upper part of the pipe elbow.

3. Effect of Scraper Length

Scraper length significantly affects the time required for the deposit remover to remove all the feeds (Figs. 9 and 10). When the scraper length is 2 cm, the feed could not be completely re-moved after 1200 sec. Increasing the scraper length up to 4.5 cm significantly reduces the time to remove all the feed. At a scraper length of 4.5 cm, it takes 250 sec to remove all the size 0 feed and 158 sec to remove all the size 3 feed. However, the time it takes to remove all the size 0 feed is not signifi-

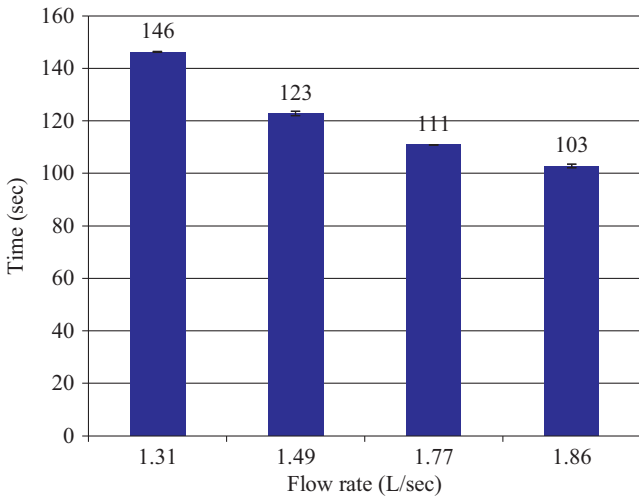

Fig. 11. Effect of flow rate on the time required for the deposit remover to rotate one turn.

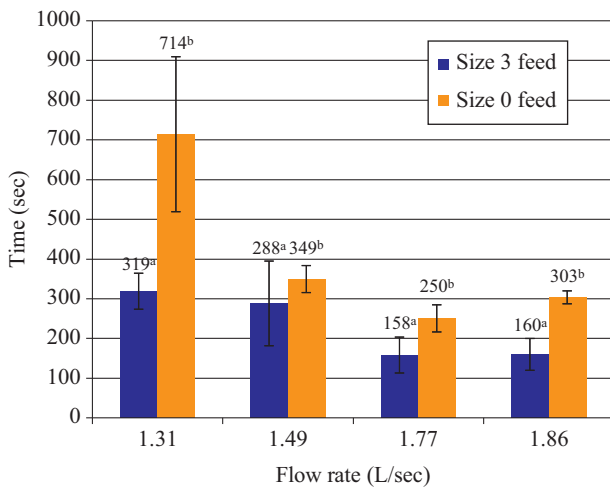

Fig. 12. Effect of flow rate on the time required to remove all the feeds.

cantly different for scraper lengths from 3.5 to 4.5 cm. The time to remove all the size 3 feed is not significantly different for scraper lengths from 4.0 to 4.5 cm. Increasing the scraper length further from 4.5 cm increases the time to remove all the feed. It is then concluded that scraper length in the range of 4.0 to 4.5 would be the optimal length for the deposit remover. All the tests afterwards then use a scraper length of 4.5 cm.

4. Effects of Flow Rate and Feed Size

Results of the flow rate tests are shown in Figs. 11-15. As expected, increasing the flow rate significantly increases the rotation speed and reduces the time needed to rotate one turn (Fig. 11). The flow rate of 1.86L/sec results in the fastest rotation speed of 103 sec per turn or 35 turns in one hour. At a flow rate of 1.31 L/sec, the time required to finish one turn increases to 146 sec, or 24.7 turns in one hour.

Fig. 12 shows the time needed to remove all the feed for

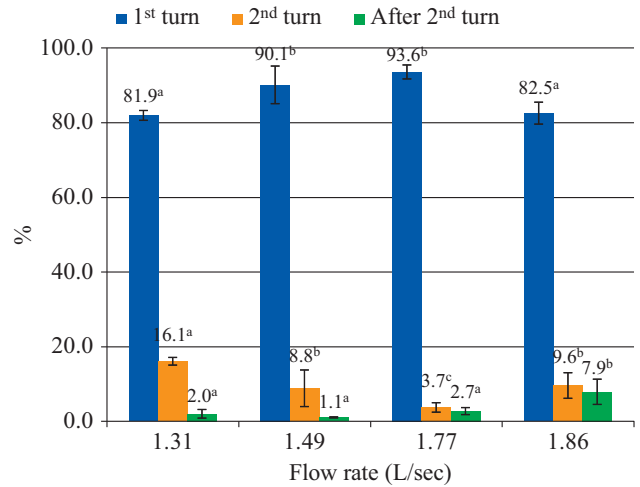

Fig. 13. The removal rate for size 0 feed in each turn.

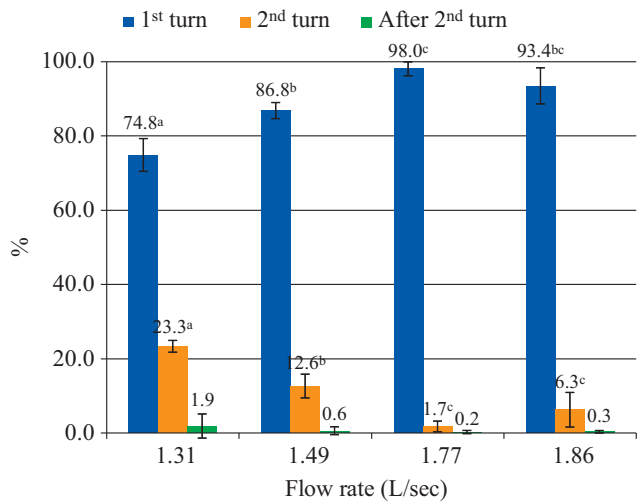

Fig. 14. The removal rate for size 3 feed in each turn.

different feed sizes and flow rates. Flow rate significantly affects the time required to remove all the feed. The flow rate of 1.31 L/sec results in the slowest removal. Increasing the flow rate from 1.49 to 1.86 L/sec does not significantly improve the time for size 0 feeds, although the flow rate of 1.77 L/sec yields the smallest average time of 250 sec. Increasing the flow rate from 1.31 L/sec to 1.49 L/sec does not significantly decrease the time for size 3 feeds. But further increase of the flow rates to 1.77 and 1.89 L/sec significantly decreases the time. The flow rate of 1.77 L/sec again yields the smallest average time to remove all size 3 feeds.

The effect of flow rate on deposit removal can be further observed from the results in Figs. 13 and 14. The flow rate significantly affects the percentage of feed that the deposit remover can remove in the first turn. At a flow rate of 1.77 L/sec, the deposit remover could remove 93.6% of the size 0 feed and 98% of the size 3 feed in the first turn. At a flow rate of 1.31 L/sec,

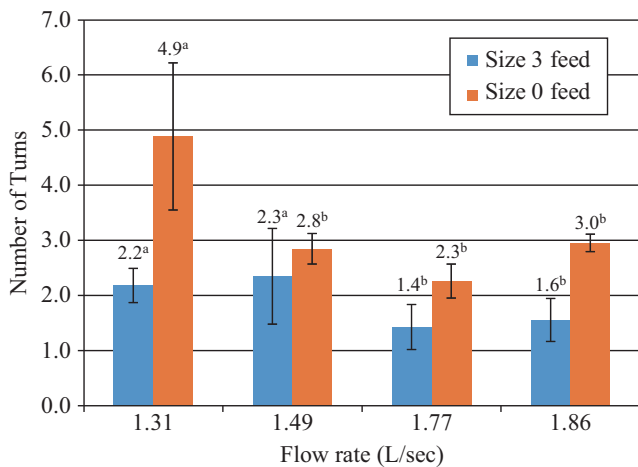

Fig. 15. Number of turns to remove all the feeds at different flow rates.

the deposit remover could remove 81.9% of the size 0 feed and 74.8% of the size 3 feed in the first turn. The deposit remover could remove 97.3% of the size 0 feed and 99.7% of the size 3 feed in the first two turns at a flow rate of 1.77 L/sec. At the smallest flow rate of 1.31 L/sec, the deposit remover could still remove 98% of the size 0 feed and 98.1% of the size 3 feed in the first two turns.

Fig. 15 shows the number of turns to remove all the feeds at different flow rates. The flow rate significantly affects the number of turns for both feed sizes. At a flow rate of 1.77 L/sec, the deposit remover could remove all the size 0 feed in an average of 2.3 turns and the size 3 feed in an average of 1.4 turns, or 4.3 min for the size 0 feed and 2.6 min for the size 3 feed. At 1.31 L/sec, the deposit remover could remove all the size 0 feed in an average of 4.9 turns and the size 3 feed in an average of 2.2 turns, or 11.9 min for the size 0 feed and 5.4 min for the size 3 feed. Increasing the flow rate from 1.49 to 1.86 L/sec does not significantly change the number of turns to remove all the size 0 feeds. Increasing the flow rate from 1.77 to 1.86 L/sec does not significantly change the number of turns to remove all the size 3 feeds.

IV. DISCUSSION

The flow pattern in the suction tube is a complex phenomenon and varies dynamically as can be observed through the transparent tube. There are many factors affecting the flow behavior making it difficult to theorize on the best design parameters before actually doing the experiments. It is interesting to observe that the distance between the propellers and the bearing holder significantly affects the rotation speed. This may be explained by noting that the bulk water flow changes direction from horizontal to vertical in the pipe elbow. The dynamic energy is therefore higher closer to the bearing holder of the upper part resulting in faster rotation of the propellers.

It is also interesting to note that one propeller is better than more propellers. This may be explained by the fact that at different positions the propellers were to run at different speeds

as previously shown. Since all the propellers are fixed to the same axle, their different requirements may create unnecessary water friction and loss of energy to reduce the overall speed.

A best scraper length of 4.5 cm for the fastest removal of the feed is found by the experiments. It is observed that further reducing the scraper length to 2 cm would increase its stiffness. As a result the height of the suction nozzles is raised to increase the distance between the nozzles and the feeds which of course would make it harder to pick up the feeds. On the other hand, when the scraper length is increased to 6 cm, the front end of the scraper tends to bend up. Then the front edge of the scrapers would push the feed instead of guiding them into the nozzles. This would also reduce the chances to pick up the feeds.

Using the best configuration from the experiment results, the deposit remover performs well in removing the deposits. In the worst case it could remove 81.9% of the size 0 feeds and 74.8% of the size 3 feeds in the first turn (Figs. 13 and 14). Both are at the flow rate of 1.31 L/sec. In only two cycles, the deposit remover could remove more than 92.1% of the size 0 feed and more than 98.1% of the size 3 feed for all the flow rates. The deposit remover could remove all the feed in less than 12 min at any flow rates tested. Fast removal of the uneaten feed could prevent them from melting and releasing substances and could reduce the chances of contaminating the water (Cripps and Bergheim, 2000). The test results are good enough to satisfy the original design intent and could make the deposit remover a practical tool to replace human labor for the bottom cleaning of recirculation culture tanks.

Comparing with previous versions of the deposit remover, the present version has made a number of useful improvements. Firstly, the entire gear box is redesigned to have a footprint half of the previous one while maintaining the original gear ratio. The new design creates a reverted gear train so that the input axle is in line with the output axle to balance the front- and back-side weight of the deposit remover to move steadier. The compound gears are easier to assemble. All the parts are designed so that they can be manufactured by injection molding to facilitate mass production.

Secondly, many adjustments are made for better performance, including changing the relative height of the driving wheel and the flexible pipe elbow to make the distance from the suction tube to the tank bottom more uniform; changing the driving wheel material to rubber to have a better friction with the tank bottom; adding a tie to the lower part of the flexible pipe elbow to clean the area around the pipe elbow; and modifying the configuration of the propeller to improve rotation speed.

Thirdly, and perhaps most importantly, is the introduction of the integrated nozzle/scraper. The previous design did not have the nozzles. Instead, a narrow slot right at the bottom of the suction tube serves to suck in water. A scraper was glued to the back of the suction tube and bend backwards (Fig. 4(b)). The problem with the previous design is that although the width of the slots is the same (7 mm), there is a vertical distance of about 5-10 mm from ground to the slot. Since the water will come into the slot from all directions, the suction force to pick up the

Table 1. Time required to remove all the feed.

Deposit remover	Flow rate (L/sec)		
	1.31	1.49	1.86
Previous design	180 ± 0.0 ^a	24 ± 0.6 ^b	14 ± 0.6 ^c
New design	5.31 ± 0.8 ^a	4.80 ± 1.8 ^b	2.66 ± 0.7 ^c

Unit: min

Table 2. Number of turns to remove the solids.

Deposit remover	Flow rate (L/sec)		
	1.31	1.49	1.86
Previous design	118.7	20.6	14.0
New design	2.2	2.3	1.6

Unit: turn

solid from the ground is less, especially when the solids are right under the slot. Therefore it would be more difficult to pick up particles on the bottom. Further, because of the lag between the scraper and the slot, the scraper could do little in helping the solids move into the slot. If the deposit remover does not pick up the solid immediately and pass over the solid, then the solid will be re-scattered by the scraper and have to wait until the next turn of the deposit remover to be picked up.

On the other hand, the new design draws in water only from the front direction. The scraper and the nozzle together form a narrow conduit to concentrate the incoming water thus raising the suction force to move the solids into the nozzles. As a result, the new deposit remover not only increases deposit removing speed but also can pick up smaller feeds down to size 0. In contrast, the previous version could only pick up feeds from size 1 up.

Table 1 compares the time required by the new deposit remover against the previous one in removing the feed at different flow rates. At a flow rate of 1.86 L/sec, the new deposit remover removes all the feed in 2.66 min, while the previous device took 14 min, or 5.3 times longer. At a flow rate of 1.49 L/sec, the new device removes all the feed in 4.8 min, while the previous device took 24 min, or 5 times longer. At a flow rate of 1.31 L/sec, the new device removes the feed in 5.31 min, while the previous device took 180 min, or 34 times longer. The improvement of the new deposit remover over the previous one is obvious.

Table 2 compares the number of turns for the new deposit remover and the previous one in removing all the feed at different flow rates. The new deposit remover rotates 2.2 turns to finish feed removal at a flow rate of 1.31 L/sec, while the previous device took 118.7 turns or 54 times more turns. At a flow rate of 1.49 L/sec, the number of turns needed to completely remove the solids by the previous deposit remover is 9 times larger. At a flow rate of 1.86 L/sec, the ratio is 8.8. These results clearly show that the improvement of the new design is phenomenal.

Table 3. Time to complete one full turn for the two versions at different flow rates.

Deposit remover	Flow rate (L/sec)			
	1.31	1.49	1.77	1.86
Previous design	130	70	65	60
New design	146	123	111	103

Unit: sec

Table 3 lists the time to complete one full turn for the two versions at different flow rates. The new deposit remover actually runs at a slower speed than the previous one for similar flow rates. This is because the driving wheel of the new deposit remover has a diameter of 7.6 cm, but the wheel of the previous deposit remover is 12.4 cm in diameter, or a 63% difference. The slower rotation speed of the new deposit remover would allow more time for the new deposit remover to remove the feed and may provide another reason for the better performance.

In this research, the flow rates tested are from 1.31 to 1.86 L/sec. Due to the experiment setup, the highest flow rate that could be obtained is 1.86 L/sec. The flow rate could go below 1.31 L/sec, but at smaller flow rates the suction force by water would drop quickly. Results of our experiments have shown that a flow rate of 1.77 L/sec obtains the best results in all the tests. At this flow rate, the water could recirculate through the 2.5 ton culture tank 61 times per day, which is more than twice as much as the normal flow rate of about 30 times per day for recirculating aquaculture systems. If the flow rate is set at 1.31 L/sec, then the recirculating rate would be 45 times per day, still higher than normal. Higher recirculation rates are not necessary for the treatment of the culture water and could increase the cost of electricity. A proper solution is to recirculate the water at a slower rate based on normal needs of water quality control. However, during the time of feeding, the flow rate could be increased by a second pump to increase the flow rate to a level suitable for the deposit remover to operate. Since the new deposit remover could finish cleaning in just few minutes, this would be a cost effective solution. The additional pump could be automatically controlled by a relay or a timer and be operated in sync with the feeder.

The deposit remover could save much time and labor in performing routine cleaning of the grouper nursery tanks. These cleaning works are instrumental in maintaining a healthy environment for the grouper fingerlings. Unlike human cleaning, the deposit remover could operate continuously. By removing the deposit as soon as they settle the water quality could be improved. Another advantage with the deposit remover is that bottom cleaning could be carried out without any direct contact with the floating cages which is inevitable if human workers are to do the job. As a result fish stress is reduced. Also, the cleaning can be done without lowering the water level in the tank and thus could save water.

The new deposit remover has been operating in a grouper nur-



Fig. 16. The worn propeller after 16 months of operation.

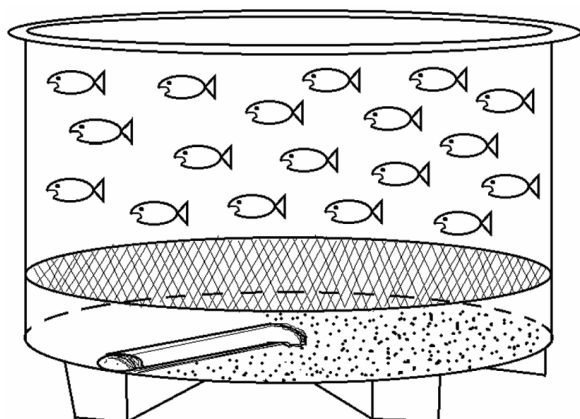

Fig. 17. A possible scheme for the use of the deposit remover. (picture courtesy of Chen, 2015)

sery tank for more than 5 months without a problem. A previous version of the deposit remover had been in use for 16 months. The only problem after such a long time was that the propeller blades could wear out (Fig. 16). The propeller costs only 80 NT and can be replaced easily by taking the deposit remover out of water and opening the pipe elbow to disassemble the old propeller and replace with a new one. Routine maintenance of the deposit remover involves only wiping the surface to remove the fouling and checking if any part is loose.

Apart from grouper nurseries, the deposit remover may be used in the culture of other species because of its advantages in routine tank cleaning as discussed above. A possible scheme is depicted in Fig. 17 where there is a net separating the cultured animals from the bottom region where the deposit remover is working. The feces from the cultured animals would drop into the bottom region and be removed quickly by the deposit remover. All is done without human labor and electricity.

IV. CONCLUSIONS

1. The results show that increasing the number of propellers of the deposit remover decreases its rotation speed. The propeller position at a distance of 2.1 cm from the bearing holder of the upper part of the pipe elbow results in the fastest rotation speed of the deposit remover. Increasing the flow rate from 1.31 to 1.86 L/sec also increases its rotation speed. A scraper length of 4.5 cm yields the fastest deposit removal rate.
2. The new deposit remover could remove more than 94% of number 0 and 3 feeds in the first turn for less than 2 min at a flow rate of 1.77 L/sec. For flow rates between 1.31 to 1.86 L/sec the deposit remover could remove all 100 grams of the feed on the tank bottom in just 12 minutes. At a flow rate of 1.77 L/sec, the deposit remover could remove 100 grams of number 0 feed in 4.2 min and number 3 feed in 2.6 min.
3. The new deposit remover improves the deposit removing efficiency by more than 5 times over the previous one making it a practical tool for the automatic bottom cleaning of grouper nursery tanks.

REFERENCES

- Chen, H.-R. (2015). Developing third generation of rotation solid substance collector on bottom by using water flow as power in indoor recirculation system. Master thesis. Department of Aquaculture, National Taiwan Ocean University. Taiwan. Republic of China. (in Chinese)
- Chen, Y.-L. (2011). The effect of rotation particle collector on the water quality of a circulation system for rearing grouper fingerlings in cage. Master thesis. Department of Aquaculture, National Taiwan Ocean University. Taiwan. Republic of China. (in Chinese)
- Cripps, S. J. and A. Bergheim (2000). Solids management and removal for intensive land-based aquaculture production system. *Aquacultural Engineering* 22, 33-56.
- Fisheries Agency, Council of Agriculture (2016). Fisheries Statistical Yearbook.
- Hseu, J.-R. (2004). The separating effect of graders used in grouper larviculture. *Journal of the Fisheries Society of Taiwan* 31, 67-71.
- Kokawa, Y., I. Takami, T. Nishizawa and M. Yoshimizu (2008). A mixed infection in sevenband grouper *Epinephelus septemfasciatus* affected with viral nervous necrosis (VNN). *Aquaculture* 284, 41-45.
- Lee, C.-W. (2012). Developing an operation procedure for growing out grouper in super-intensive recirculation system *Epinephelus coioides*. Master thesis. Department of Aquaculture, National Taiwan Ocean University. Taiwan. Republic of China. (in Chinese)
- Lin, H.-F. (2013). Development of rotation solid substance collector on bottom by using water flow as power in indoor recirculation system for grouper nursery. Master thesis. Department of Aquaculture, National Taiwan Ocean University. Taiwan. Republic of China. (in Chinese)
- Ma, H., J. Xie, S. Weng, T. Zhou and J. He (2012). Co-infection of megalocytivirus and viral nervous necrosis virus in a very severe mass mortality of juvenile orange-spotted groupers *Epinephelus coioides*. *Aquaculture* 358, 70-175.
- Müller-Belecke, A., S. Zienert, U. Spranger and A. Spranger (2015). Development of special equipment for efficient hatchery production and handling of juvenile pikeperch, Proceedings of Aquaculture Europe 2015, Rotterdam, The Netherlands.
- Puri, S. C. and K. Mullenm (1980). Multiple comparisons. In: Applied Statistics for Food and Agriculture Scientists. G K Hall & Co, Boston MA. 146-162.
- Sheen, S.-S., A.-C. Cheng, P.-C. Liu, C.-H. Lin and F.-H. Nan (2014). Status and trend of Taiwan grouper industry (in Chinese). *Aquaculture Biotech* 38, 1-7.

Yang, H.-L. (2017). Grouper farming: current bottleneck and new technology. *The Aquaculturists*. March 2017. 36-40.

Yanz, C.-C. (2010). The effect of air-lift particle collector and feeding strategy on

the water quality of a semi-circulation system for rearing grouper fingerlings in cage. Master thesis. Department of Aquaculture, National Taiwan Ocean University. Taiwan. Republic of China. (in Chinese)